

**CODE OF PRACTICE**

**ON**

**SURFACE WATER DRAINAGE**



**Seventh Edition - Dec 2018**  
**with amendments under**  
**Addendum No. 2 – Oct 2023**

# CODE OF PRACTICE

## ON

### SURFACE WATER DRAINAGE

(Seventh Edition – Dec 2018)

#### Addendum No. 2 – October 2023

This addendum shall be read in conjunction with the Code of Practice on Surface Water Drainage (Seventh Edition - Dec 2018) and shall form part of the Code of Practice.

S/No.	Part/ Page No.	Amendments/Corrections
1	Terminology/ Page 2	Insert new terminology:  <b>“Critical Infrastructure” (CI)</b>  refers to physical infrastructure and assets that are vital to the continued delivery of the essential services that Singapore relies on, the loss or compromise of which would lead to a debilitating impact on security, economy or public health and safety;
2	Terminology/ Page 2	Insert new terminology:  <b>“Critical M&amp;E Equipment”</b>  <i>refers to power (e.g. distribution substations, transformers, standby generator sets), communication (e.g. main distribution frame rooms, server rooms) and other M&amp;E equipment deemed as critical by the asset owner;</i>
3	Terminology/ Page 2	Insert new terminology:  <b>“Key Infrastructure” (KI)</b>  <i>refers to developments that fall outside the definition of a critical infrastructure, but are identified by agencies to be important to agencies’ function, such as distribution substations (22kV, 6.6kV), prison complexes, bus interchange and depots, and neighbourhood police centres;</i>
4	Terminology/ Page 3	Insert new typologies for <b>“Special Facilities”</b> :  refers to developments such as Rapid Transit systems, port/aviation facilities, wafer fabrication plants, underground road networks, power generation plants, healthcare with A&E services, gas transmission/ receiving station, <i>transmission substations, exchange or central office used for telecommunication purpose</i> , or any developments as specified by the Board

5	Clause 2.1.1 (b)(iii)/ Page 6	<p>Replace:</p> <p>(iii) Any other level as may be specified by the Board;</p> <p><i>with</i></p> <p>(iii) 300mm above modelled flood levels (as advised by the Board) if the development is a CI or KI; or</p> <p>(iv) Any other level as may be specified by the Board;</p>
6	Clause 2.1.1 (c)(iii)/ Page 7	<p>Replace:</p> <p>(iii) Any other level as may be specified by the Board;</p> <p><i>with</i></p> <p>(iii) 300mm above modelled flood levels (as advised by the Board) if the development is a CI or KI; or</p> <p>(iv) Any other level as may be specified by the Board;</p>
7	Clause 2.2 (c)/ Page 9	<p>Replace:</p> <p><u>Underground Special Facilities and Developments with Direct or Indirect Linkages to Underground Special Facilities</u></p> <p><i>with</i></p> <p><u>Special Facilities and Developments with Direct or Indirect Linkages to Special Facilities</u></p>
	Clause 2.5/ Page 10	<p>Insert new Clause 2.5:</p> <p><b>2.5 Critical M&amp;E Equipment in Critical Infrastructure / Key Infrastructure</b></p> <p><i>The QP shall advise the developer/owner on the need to identify power, communications, and other critical M&amp;E equipment prior to the design of the development site.</i></p> <p><i>Critical M&amp;E equipment shall be located /installed at the minimum platform level or higher.</i></p> <p><i>For critical M&amp;E equipment located at the basement, the structural crest level for all entrances, exits and openings leading to the basement must comply with crest level requirements as stipulated in Clause 2.2.</i></p>
8	Clause 4.3.3/ Page 12	<p>Replace:</p> <p>Only box culverts shall be provided. The internal width and clear depth of a box culvert shall be at least 0.6 m. For culverts across expressways and semi-expressways, the minimum size shall be 1.0 m x 1.0 m.</p> <p><i>with</i></p> <p>Only box culverts shall be provided. The internal width and clear depth of a box culvert shall be at least 1.0 m. For culverts across expressways and semi-expressways, the minimum size shall be 2.0 m (width) x 1.5 m (depth).”</p>

9	Clause 6.3.3/ Page 21	<p>Replace:</p> <p><b>Permit to Start Earthworks</b> The site operator/contractor shall obtain a written permission (or a clearance certificate) from the Board and implement adequate ECM before the commencement of any earthwork.</p> <p><i>with</i></p> <p><b>Approval to Start Earthworks</b> The site operator/contractor shall obtain <i>approval</i> from the Board and implement adequate ECM before the commencement of any earthwork.</p>
10	Clause 7.1.5 (a)/ Page 29	<p>Replace:</p> <p>New erection and reconstruction works to commercial, industrial, institutional and residential developments greater than or equal to 0.2 hectares in size</p> <p><i>with</i></p> <p>New erection and reconstruction works to <i>all</i> developments greater than or equal to 0.2 hectares in size</p>
11	Clause 7.1.5 (b)/ Page 29	<p>Replace:</p> <p>Additions &amp; Alterations (A&amp;A) works to existing commercial, industrial, institutional and residential developments where affected area is greater than or equal to 0.2 hectares in size such as:</p> <p><i>with</i></p> <p>Additions &amp; Alterations (A&amp;A) works to <i>all</i> existing developments where affected area is greater than or equal to 0.2 hectares in size such as:</p>
12	Clause 7.1.5 (i)/ Page 29	<p>Insert new feature:</p> <p>(i) Detention tanks/<i>drains</i>;</p>

14	Clause 8.2.2/ Page 33	<p>Replace:</p> <p>The developer/ owner shall engage an ABC Waters (Active, Beautiful, Clean Waters) Professional to design, oversee the construction of, and develop a maintenance plan for the ABC Waters design features.</p> <p>The developer/owner shall submit the concept design and design calculations, endorsed by the ABC Waters Professional, to the Board as part of DC submission.</p> <p>Hydraulic calculations associated with the ABC Waters design features, endorsed by an ABC Waters Professional who is a PE (Civil), shall be submitted at DC stage.</p> <p>If there is any change to the catchment or design of the ABC Waters design features subsequent to DC approval, QP shall submit the updated design and hydraulic calculations associated with the ABC Waters design features, duly endorsed by an ABC Waters Professional who is a PE (Civil).</p> <p><i>with</i></p> <p>The developer/ owner shall engage an ABC Waters (Active, Beautiful, Clean Waters) Professional to <i>plan</i>, design, oversee the construction of, and develop a maintenance plan for the ABC Waters design features.</p> <p><i>For developments of area exceeding 0.4 hectares, DC submissions for ABC Waters design features, comprising the following items, should be submitted to the Board as part of DC submission:</i></p> <ul style="list-style-type: none"> <li><i>(a) Hydraulic calculations for the ABC Waters design features, endorsed by an ABC Waters Professional who is a PE (Civil). The calculation shall be accompanied by completed relevant design templates in Excel format, available on the PUB website.</i></li> <li><i>(b) Catchment/location plan of ABC Waters design features endorsed by an ABC Waters Professional who is an Accredited Landscape Architect or a registered Professional Architect.</i></li> <li><i>(c) Design drawings and maintenance checklists endorsed by an ABC Waters Professional of any profession.</i></li> </ul> <p>If there is any change to the catchment or design of the ABC Waters design features subsequent to DC approval, QP shall submit <i>a DC amendment with the full set of updated items (a), (b) and (c) above with respective endorsement and a summary table for all the amendments.</i></p>
----	--------------------------	---

15	Clause 9.4/ Page 34	<p>Replace:</p> <p>Drains shall enter the sump at angles less than a right angle and at different levels wherever possible.</p> <p><i>with</i></p> <p>Drains <i>connecting into</i> the sump shall not form an acute angle with the outgoing drain flow and shall connect at different levels wherever possible.</p>
16	Clause 9.8.1/ Page 35	<p>Replace:</p> <p>Drop-inlet chambers and concealed scupper drainage shall be designed in accordance with the Land Transport Authority's latest Standard Details of Road Elements and shall be provided at maximum 6 m spacings along all road carriageways.</p> <p><i>with</i></p> <p>Drop-inlet chambers and concealed scupper drainage shall be designed in accordance with the Land Transport Authority's latest Standard Details of Road Elements and shall be provided at maximum 6 m spacings along all road carriageways. <i>Intermediate sump shall be provided if the length of the concealed scupper drainage exceeds 6m.</i></p>
17	Clause 9.9/ Page 35	<p>Replace “Type B” railings <i>with</i> “Type A” railings.</p>
18	Clause 9.12.2/ Page 37	<p>Replace:</p> <p>Under the exceptional circumstance where the entrance culvert/crossing is shallower than 600 mm or when requested by the Board, hinged open gratings shall be installed throughout the whole length of the entrance culvert/crossing.</p> <p><i>with</i></p> <p>Under the exceptional circumstance where the entrance culvert/crossing is shallower than 600 mm or when requested by the Board, <i>one number</i> of hinged open gratings <i>as per Drawing no. 7C</i> shall be installed <i>in the middle</i> of the entrance culvert/crossing.</p>
19	Drawing No.7C Page 60	<p>Insert new drawing 7C</p>

CODE OF PRACTICE  
ON  
SURFACE WATER DRAINAGE

Public Utilities Board would like to thank the following Professional Institutions and agencies for their invaluable advice and comments on the Code of Practice on Surface Water Drainage (Seventh Edition):

Professional Bodies:

Association of Consulting Engineers, Singapore (ACES)

The Institution of Engineers, Singapore (IES)

Singapore Institute of Architects (SIA)

Singapore Institute of Landscape Architects (SILA)

Agencies

Building and Construction Authority (BCA)

Centre for Public Project Management (CP2M)

Housing & Development Board (HDB)

JTC Corporation (JTC)

Land Transport Authority (LTA)

National Environment Agency (NEA)

National Parks Board (NParks)

Singapore Civil Defence Force (SCDF)

Urban Redevelopment Authority (URA)

<b>CONTENTS</b>		<b>Page</b>
<b>Introduction</b>		
<b>Terminology</b>		
<b>PART I PLANNING REQUIREMENTS</b>		
<b>1</b>	<b>Drainage Reserve</b>	
1.1	Drainage Reserve Requirements	5
1.2	Realignment of Drainage Reserve	5
1.3	Use of Drainage Reserve	5-6
<b>2</b>	<b>Platform, Crest and Reclamation Levels</b>	
2.1	Minimum Platform Level	6-8
2.2	Crest Level	9
2.3	Minimum Reclamation Level	9
2.4	Flood Protection Measures	10
2.5	Critical M&E Equipment in Critical Infrastructure/ Key Infrastructure	10
<b>3</b>	<b>Flood Protection of underground Rapid Transit Systems, Vehicular Underpass, Road Tunnels and Their Ancillary Buildings</b>	
3.1	Principles and Standards of Protection	11
3.2	Developments with Direct/ Indirect Linkages to Underground Rapid Transit Systems, Vehicular Underpasses, Road Tunnels and Their Ancillary Buildings	11
<b>4</b>	<b>Drainage Planning Requirements</b>	
4.1	Drains Not to be Interfered with	12
4.2	Drainage Affecting Other Premises	12
4.3	Closed Drainage System	12
4.4	Internal Drainage System	12-13
4.5	Common Drain	13
4.6	Improvements to Existing Drain	13
4.7	Structure Over Roadside Drain/Outlet Drain	13
4.8	Hydraulic & Structural Calculations	13-14
4.9	Drainage for Underground Facilities	14
4.10	Drainage at Reclaimed Land	15
4.11	Outfall Structure for Drain Connecting to the Sea	15
<b>5</b>	<b>Structures Within or Adjacent to Drain/Drainage Reserve</b>	
5.1	No Structure within Drain/Drainage Reserve	16
5.2	Drain Connection within Drainage Reserve	16
5.3	Embankments and Structures adjacent to Drain/Drainage Reserve	16-17
5.4	Structure Within/Across Drain/Drainage Reserve	17-18
5.5	Services Within and/or Across Drain/Drainage Reserve	18-19
<b>6</b>	<b>Requirements for Construction Activities</b>	
6.1	General Requirements	20
6.2	Laying and Diversion of Services	21
6.3	Earth Control Measures (ECM)	21-24
6.4	Earthworks	25
6.5	Road Works	25
6.6	Reclamation Works	25



## **PART II      DESIGN REQUIREMENTS**

<b>7</b>	<b>Drainage Design and Considerations</b>	
7.1	Computation of Peak Runoff	27-29
7.2	Computation of Discharge Capacity	30
7.3	Design Considerations	31
<b>8</b>	<b>Integration of Adjacent Watercourses with Developments and ABC Waters Design Features within Developments</b>	
8.1	Integration of Adjacent Watercourses with Developments	32
8.2	Integration of ABC Waters Design Features within Developments	32-33
<b>9</b>	<b>Drainage Structures and Facilities</b>	
9.1	Drain and Culvert	34
9.2	Transition	34
9.3	Curves and Bends	34
9.4	Sump for Drain Intersections	34
9.5	Drain Connection to Existing Drain	34
9.6	Maintenance Access for Drainage Reserve	35
9.7	Markers along Edge of Drainage Reserve	35
9.8	Drop-inlet Chambers, Inlet Openings and Slot-Outlets	35
9.9	Safety Railings	35
9.10	Rungs in Drains	35
9.11	Grating over Closed Drain/Culvert	36
9.12	Entrance Culvert/Crossing	37
9.13	Live Loads on Drains	37
<b>10</b>	<b>Pumped Drainage System</b>	<b>38-39</b>

**PART III      ENSURING THE INTEGRITY OF STORM WATER DRAINAGE SYSTEMS**

11	<b>Temporary Occupation Permit (TOP)</b>	
11.1	Compliance during Temporary Occupation Permit (TOP)	41
12	<b>Certificate of Statutory Completion (CSC)</b>	
12.1	Drainage Works According to Approved Plan	42
12.2	Supervision	42
12.3	Completion of Works	42
12.4	“As-Constructed” Drainage Drawing and Piling Record	42
12.5	Survey Plan	42
12.6	Defects Liability Period	43
12.7	Handing-over of Drain	43
13	<b>Maintaining the Integrity of Storm Water Drainage Systems including Flood Protection Measures</b>	
13.1	Responsibility of Developer/Owner/Managing Agent/MCST/Town Council	44
13.2	Declaration on Storm Water Drainage Systems	44

## **Appendices**

Appendix 1	Drainage Reserve Requirements
Appendix 2	Submission Requirements for Flood Protection Measures
Appendix 3	Principles and Standards for Flood Protection of Underground Rapid Transit Systems, Vehicular Underpasses, Road Tunnels and their Ancillary Buildings
Appendix 4	Rainfall Intensity- Duration- Frequency Curves for Singapore Island
Appendix 5	Submission Requirements for “As Constructed” Drainage Drawings

## **Drainage Standard Drawings**

Drawing No. 1	Typical Details of Roadside Drain Elements
Drawing No. 2	Standard Details of 4m x 2m Grating
Drawing No. 3	Standard Details of Maintenance Access within Drainage Reserve, Access Shaft Opening and Layout Plan of Roadside Drop Inlet-Chambers and Scupper Pipe Drains
Drawing No. 4	Drainage Reserve Marker, Bollard and Posts & Chains
Drawing No. 5	Enhanced Drop Inlet-Chambers
Drawing No. 6	Standard Safety Railings
Drawing No. 7A	Typical Details of Pedestrian Gratings
Drawing No. 7B	Typical Details of Vehicular Gratings
Drawing No. 7C	Typical Details of Entrance Culvert Gratings
Drawing No. 8	Earth Control Measures at Construction Site

CODE OF PRACTICE  
ON  
SURFACE WATER DRAINAGE

INTRODUCTION

Singapore is situated close to the equator and is subjected to heavy tropical rainstorms. The average annual rainfall in Singapore is about 2,340 mm. There are no distinct wet or dry seasons as rain falls every month of the year. The two main seasons, the North-east monsoon season (from late November to March) and the South-west monsoon season (from late May to September) refer to the prevailing winds dominant at the time of the year. The transitional months (or Inter-monsoon period) separating the two monsoons are April to early May, and October to early November.

The total land area of Singapore is approximately 721.5 km<sup>2</sup> (as at 2017). This area comprises the mainland and other islands. The mainland measures 50 km from east to west and 27 km from north to south with a coastline of 193 km. The topography of the main island of Singapore is undulating with its highest point, the Bukit Timah Peak at only 165 m above mean sea level. Much of Singapore lies within 15 m of mean sea level and the ground levels of some 30% of Singapore are less than 5 m above mean sea level.

This Code of Practice on Surface Water Drainage is issued under Section 32 of the Sewerage and Drainage Act (Chapter 294). It specifies the minimum engineering requirements for surface water drainage for new developments. The Qualified Persons shall ensure that all aspects of surface water drainage are effectively taken care of in their planning, design and implementation of the development proposals.

Public Utilities Board  
Singapore

## TERMINOLOGY

- “ABC Waters Design features”** are environmental friendly features that detain and treat storm water runoff using natural elements like plants and soil filter media. They improve storm water runoff quality, enhance the aesthetics and biodiversity of the surrounding environment as well as slow down the flow of storm water runoff;
- “ABC Waters Professionals”** are Professional Engineers, Professional Architects or Accredited Landscape Architects who are registered with The Institution of Engineers Singapore (IES), Singapore Institute of Architects (SIA) or the Singapore Institute of Landscape Architects (SILA) respectively as ABC Waters Professionals;
- "Architect"** means a person who is registered under the Architects Act 1991 and has in force a practising certificate issued under that Act;
- "Board"** means the Public Utilities Board reconstituted under Section 3 of the Public Utilities Act 2001 (Act 8 of 2001);
- “Catchment”** means the area which drains into a storm water drainage system;
- "Common Drain"** refers to a drain of less than 1.0 m wide serving more than one premises and is not located within Road Reserve;
- "Crest Level"** means the bottom level of any openings (including ventilation and services openings) or summit level of a ramp or accessway leading into or away from an underground or basement structure or facility, including the summit level of any exits from the underground facilities;
- “Critical Infrastructure” (CI)** refers to physical infrastructure and assets that are vital to the continued delivery of the essential services that Singapore relies on, the loss or compromise of which would lead to a debilitating impact on security, economy or public health and safety;
- “Critical M&E Equipment”** refers to power (e.g. distribution substations, transformers, standby generator sets), communication (e.g. main distribution frame rooms, server rooms) and other M&E equipment deemed as critical by the asset owner;
- "Drain"** includes any canal, culvert, conduit, river or watercourse;
- "Drainage Reserve"** means any land set aside for drainage works pursuant to development proposals approved by a competent authority;
- "Drainage Works"** includes any engineering works for the construction, alteration and maintenance of any storm water drainage system;
- "General Developments"** refers to developments other than Industrial/Institutional/Commercial/Multi-Unit Residential Developments and Special Facilities;
- "Internal Drain"** refers to a drain serving only the premises;
- "Industrial/ Institutional/ Commercial/ Multi-Unit Residential Developments"** refers to developments where commercial activity takes place, or buildings with more than one dwelling unit including but not limited to shopping malls, large office buildings, condominiums and hotels;

- “Key Infrastructure” (KI)** refers to developments that fall outside the definition of a critical infrastructure, but are identified by agencies to be important to agencies’ function, such as distribution substations (22kV, 6.6kV), prison complexes, bus interchange and depots, and neighbourhood police centres;
- "Outlet Drain"** refers to a drain within a drainage reserve;
- "Platform Level"** means the general ground level of a proposed development;
- "Professional Engineer" (PE)** means a person who is registered under the Professional Engineers Act 1991 and has in force a practising certificate issued under that Act;
- "Qualified Person" (QP)** means a person who is an Architect or a Professional Engineer or a suitably qualified person registered under other relevant legislation;
- "Qualified Erosion Control Professional" (QECP)** means a Professional Engineer who is registered under the Professional Engineers Act Chapter 253, has in force a practicing certificate issued under that Act, and has satisfactorily completed a specialized professional course in erosion and sediment control;
- "Reclamation Level"** means the filled level of a reclamation site;
- "Roadside Drain"** refers to a drain within the land set aside for drainage in a Road Reserve;
- "Special Facilities"** refers to developments such as Rapid Transit systems, port/aviation facilities, wafer fabrication plants, underground road networks, power generation plants, healthcare with A&E services, gas transmission/ receiving station, transmission substations, exchange or central office used for telecommunication purpose or any developments as specified by the Board;
- "Storm Water Drainage System"** means a system of drains for the conveyance or storage of storm water and includes
- (a) any weir, grating, float boom, gauge, tidegate, sump, storage pond, pumping station, maintenance access and debris interception and removal facility related to such system;
  - (b) any structure constructed to convey, store or measure storm water or for flood alleviation; and
  - (c) any bridge over or railing for any such drain or any appurtenance thereof;

# **CODE OF PRACTICE ON SURFACE WATER DRAINAGE**

## **PART I**

### **PLANNING REQUIREMENTS**

- 1 Drainage Reserve
- 2 Platform, Crest and Reclamation Levels
- 3 Flood Protection of At-Grade and Underground Rapid Transit Systems, Vehicular Underpasses, Road Tunnels and Their Ancillary Buildings
- 4 Drainage Planning Requirements
- 5 Structures Within or Adjacent to Drain/Drainage Reserve
- 6 Requirements for Construction Activities

# CODE OF PRACTICE ON SURFACE WATER DRAINAGE

## PART I

### PLANNING REQUIREMENTS

#### 1 DRAINAGE RESERVE

##### 1.1 Drainage Reserve Requirements

- 1.1.1 The width of a drainage reserve is based on the required drain size as shown in Appendix 1.
- 1.1.2 The drainage reserve shall be delineated as a separate plot in Urban Redevelopment Authority's (URA) Written Permission to be subsequently vested or surrendered to State.
- 1.1.3 Land set aside as drainage reserve shall be kept free of all encumbrances.

##### 1.2 Realignment of Drainage Reserve

- 1.2.1 A drainage reserve may be realigned subject to the following conditions:
  - (a) The proposed drain diversion is technically and physically feasible and acceptable to the Board; and
  - (b) The developer/owner shall construct the proposed drain to the size as determined by the Board.

##### 1.3 Use of Drainage Reserve

- 1.3.1 Under special circumstances, the developer/owner may be allowed the use of the drainage reserve subject to the following conditions:
  - (a) The developer/owner shall allow the Board or the Board's agent access to carry out drainage works within the drainage reserve as and when necessary;
  - (b) The developer/owner shall not construct any structures or facilities on, over or under the drainage reserve;
  - (c) The developer/owner shall be responsible for the physical maintenance of the land and storm water drainage system within the drainage reserve;
  - (d) The developer/owner shall be responsible for the structural maintenance of the storm water drainage system within the drainage reserve;
  - (e) The developer/owner shall be responsible for public safety within the drainage reserve;
  - (f) The developer/owner shall at all times indemnify and keep indemnified the Government fully and completely against all liabilities of whatsoever nature and description which may be incurred or suffered by the Government in connection with or arising out of the use of the drainage reserve by the developer/owner and against all actions, proceedings, claims, costs and expenses therefrom;
  - (g) The Board reserves the right to rescind the approval for the use of drainage reserve as and when required by the Board for drainage works and without the need for reinstatement of the affected facilities;
  - (h) The developer/owner shall be responsible for safeguarding the structural integrity of the affected storm water drainage system within the drainage reserve when carrying out the work; and



- (i) The developer/owner shall reinstate or rectify any damage to the storm water drainage structures caused by their work at their own cost and to the Board's satisfaction upon the completion of the work.
- (j) Any additional conditions deemed necessary by the Board.

## 2 PLATFORM, CREST AND RECLAMATION LEVELS

### 2.1 Minimum Platform Level

The minimum platform level of a development site as specified by the Board is the required minimum ground level of that proposed development. The platform levels shall be indicated on the layout plans.

The minimum platform level required for a proposed development depends on its locality and the type of development, as categorised below:

#### 2.1.1 Type of Development

##### (a) General Developments

The minimum platform level shall not be lower than:

- (i) 4.0m above Singapore Height Datum for developments along the southern coast; and  
4.5m above Singapore Height Datum for developments along the northern coast; or
- (ii) 300 mm above the adjacent road/ground level; or
- (iii) Any other level as may be specified by the Board;

whichever is the highest.

##### (b) Industrial/ Institutional/Commercial/Multi-Unit Residential Developments

The minimum platform level shall not be lower than:

- (i) 4.0m above Singapore Height Datum for developments along the southern coast; and  
4.5m above Singapore Height Datum for developments along the northern coast; or
- (ii) 600 mm above the adjacent road/ground level; or
- (iii) 300mm above modelled flood levels (as advised by the Board) if the development is a CI or KI; or
- (iv) Any other level as may be specified by the Board;

whichever is the highest.

(c) Special Facilities and Developments with Direct or Indirect Linkages to Underground Special Facilities

The minimum platform level shall not be lower than:

- (i) 4.0m above Singapore Height Datum for developments along the southern coast; and  
4.5m above Singapore Height Datum for developments along the northern coast; or
- (ii) 1 m above the adjacent road/ground level; or
- (iii) 300mm above modelled flood levels (as advised by the Board) if the development is a CI or KI; or
- (iv) Any other level as may be specified by the Board;

whichever is the highest.

2.1.2 **Exception Cases**

If, subject to approval of the Board, the minimum platform levels as specified in Clause 2.1.1 cannot be met, the following conditions (a) and (b) must be met:

- (a) The platform level of the building structure must be at least:
  - (i) 3.5 m above Singapore Height Datum for developments along the southern coast; and  
4.0 m above Singapore Height Datum for developments along the northern coast; or

whichever is higher

**and;**

- (b) Flood protection measures must be included in the design to provide at least the same level of flood protection that the minimum platform and/or crest levels would provide for the building. Details of proposed flood protection measures should be submitted to the Board for approval. Implementation of the flood protection measures shall comply with the requirements stipulated in Clause 2.4.

Notwithstanding the above, the Qualified Person shall advise the developer/owner to raise the platform level and/or crest level to the highest possible levels before considering the deployment of flood protection measures. In addition, the developer/owner shall be advised that the development site may be subjected to flood risks despite the implementation of flood protection measures.

### 2.1.3 Compliance with Minimum Platform Levels

- (a) All new development proposals including reconstruction proposals shall comply with the requirements for minimum platform levels except those listed in Clause 2.1.3(b).
- (b) The following proposals need not comply with the required minimum platform levels:
  - (i) Addition & alteration (A&A) works to an existing building where there are no direct and/or indirect linkages to underground special facilities;
  - (ii) Partial reconstruction works to an existing building involving only the building of additional floors without reconstruction of the first storey and where there are no direct and/or indirect linkages to underground special facilities;
  - (iii) Conservation projects;
  - (iv) Temporary development works intended for use for a temporary period;
  - (v) Any other works as may be specified by the Board.

For these development proposals, the Qualified Person shall advise the developer/owner that the minimum platform levels are still recommended as a protection measure to reduce flood risks. If lower platform levels are adopted, the developer/owner shall be advised that the development site may be subjected to higher flood risks. The developer/owner should consider installing flood protection measures where possible (See Clause 2.4 and Clause 13).

### 2.1.4 Ancillary Areas

- (a) Where the minimum platform levels for developments in low-lying areas are significantly higher than the adjacent road/ground levels, the Qualified Person may apply in writing to Board for approval to construct the ancillary areas at below the minimum platform levels so as to tie-in with the adjacent low-lying road/ground levels or to satisfy other planning and environmental considerations.

Notwithstanding the above, the Qualified Person shall advice the developer/owner that the platform level adopted for the ancillary areas should be as reasonably high as possible.

- (b) Ancillary areas include:
  - (i) Entrance driveways;
  - (ii) Bin centres;
  - (iii) Turfed compound areas;
  - (iv) Car porch/porches for single unit development(s); and
  - (v) Other areas as may be approved by the Board.

## **2.2 Crest Level**

Crest level is required for all entrances, exits or openings to basement(s) or underground structures (e.g. tunnels, underground facilities). The minimum crest level required depends on the type of development, as categorised below:

(a) Basements of General Developments

The minimum crest level shall be at least 150 mm above the minimum platform level as specified in Clause 2.1.1(a).

(b) Basements of Industrial/Institutional/Commercial/Multi-Unit Residential Developments

The minimum crest level shall be at least 300 mm above the minimum platform level as specified in Clause 2.1.1 (b).

(c) Special Facilities and Developments with Direct or Indirect Linkages to Special Facilities,

The minimum crest level shall be at least 300 mm above the minimum platform level as specified in Clause 2.1.1 (c).

## **2.3 Minimum Reclamation Level**

For land reclamation works, the minimum reclamation level shall not be lower than:

- (i) 4.0 m above Singapore Height Datum for developments along the southern coast; and  
4.5 m above Singapore Height Datum for developments along the northern coast; or
- (ii) Any other levels as may be specified by the Board.

The platform levels required for any development subsequently carried out on the reclaimed land shall be higher than the reclamation level and shall be separately determined by the developer/owner's Qualified Person to ensure effective internal drainage of the development site.

## 2.4 Flood Protection Measures

Flood protection measures as stipulated under Clauses 2.1.2(b), 2.1.3(b) and 2.2 shall comply with the following requirements, including those stipulated in Clause 13 and Appendix 2:

(a) General Development

Flood protection measures shall be provided at all points of entry, exit and all openings (including windows, ventilation and services openings) for the building premises (at ground/platform level).

(b) Industrial/Institutional/Commercial/Multi-Unit Residential Developments, Special Facilities and Developments with Direct or Indirect Linkages to Underground Special Facilities

Flood protection measures shall be provided at:

- (i) At all points of entry, exit and all openings (including windows, ventilation and services openings) for the building premises (at ground/platform level); or
  - (ii) All points of entry and exit for the entire development area.
- (c) The developer/owner shall obtain the necessary clearance from relevant authorities to install the flood protection measures during the Development Control (DC) stage for approval.
- (d) Details of the flood protection measures and Standard Operating Procedure (SOP) should be submitted to the Board during Detailed Plan (DP) stage for record.

## 2.5 Critical M&E Equipment in Critical Infrastructure / Key Infrastructure

The QP shall advise the developer/owner on the need to identify power, communications, and other critical M&E equipment prior to the design of the development site.

Critical M&E equipment shall be located /installed at the minimum platform level or higher.

For critical M&E equipment located at the basement, the structural crest level for all entrances, exits and openings leading to the basement must comply with crest level requirements as stipulated in Clause 2.2.

### **3 FLOOD PROTECTION OF UNDERGROUND RAPID TRANSIT SYSTEMS, VEHICULAR UNDERPASSES, ROAD TUNNELS AND THEIR ANCILLARY BUILDINGS**

#### **3.1 Principles and Standards of Protection**

A higher level of protection against flood risks is required for the underground Rapid Transit Systems, vehicular underpasses, road tunnels and their ancillary buildings. The principles and standards of protection are outlined in Appendix 3.

#### **3.2 Developments with Direct/Indirect Linkages to Underground Rapid Transit Systems, Vehicular Underpasses, Road Tunnels and Their Ancillary Buildings**

All developments with direct/indirect linkages to the underground Rapid Transit Systems, vehicular underpasses, road tunnels and their ancillary buildings shall have the same protection requirements as stated in Clause 2.1.1(c) and Clause 2.2(c). All development proposals (including addition & alteration (A&A) and reconstruction proposals) having such linkages shall be submitted to the Board for approval.

## **4 DRAINAGE PLANNING REQUIREMENTS**

### **4.1 Drains Not to be Interfered with**

No drain shall be interfered with or altered without the approval of the Board.

### **4.2 Drainage Affecting Other Premises**

4.2.1 All runoff from the development site shall be discharged into a roadside drain or an outlet drain and not into the adjacent premises. A minimum 600 mm high solid wall shall be erected along the boundary of the development site abutting adjacent premises to prevent surface runoff from overflowing into adjacent premises.

4.2.2 Where the runoff from the development site is discharged through an existing or proposed drainage outlet to the adjacent premises, the downstream drain at the adjacent premises must be able to cope with the runoff from the development site. The developer/owner may be required to upgrade the downstream drain to the required size as determined by the Board. The Qualified Person shall liaise with the downstream owner(s) before implementing the drainage proposal.

4.2.3 Where there is existing runoff flowing from adjacent premises or roads into or through the development site, the runoff shall continue to be allowed to discharge through the development site.

4.2.4 If a development site is sloping towards the adjacent premises, a drainage system shall be provided along the site boundary to prevent the runoff from discharging into adjacent premises.

### **4.3 Closed Drainage System**

4.3.1 The internal width and clear depth of a roadside drain (including entrance culvert) shall be at least 600 mm.

4.3.2 The provision of gratings, openings and chequered plates for closed drains shall comply with Clause 9.11.

#### **4.3.3 Culverts Across Roads**

Only box culverts shall be provided. The internal width and clear depth of a box culvert shall be at least 1.0 m. For culverts across expressways and semi-expressways, the minimum size shall be 2.0 m (width) x 1.5 m (depth).

### **4.4 Internal Drainage System**

4.4.1 Internal drains shall be designed with sufficient capacity and openings to intercept and discharge all runoff from the development site.

4.4.2 Internal drains shall be designed for safety and ease of maintenance.

4.4.3 Prior to discharging any storm water within the development site to the roadside/outlet drain, vertical grating(s) shall be installed at the outlet discharge point(s) of the internal drain(s) located within the development site.

#### 4.4.4 Internal Conduit Drain

Where the open backyard area of each intermediate terraced development is not linked to the front yard by a corridor at ground level, a conduit drain for conveying surface runoff may run beneath the building itself. The conduit drain shall be at least 300 mm in diameter. The conduit drain shall be laid straight without any bend or sag in its alignment. At both the inlet and outlet ends of the conduit drain, maintenance sumps shall be provided with invert level drops of at least 150 mm deep. The conduit drain shall be fully supported along its entire length by (and not attached to) the ground beams of the building and shall form as part of the permanent structure of the building to ensure against settlement.

#### 4.4.5 Drainage for Air Wells/ Courtyards

Conduit drains serving the air wells or courtyards shall be designed to cater for the runoff and shall be at least 150 mm in diameter. Maintenance sump(s) should also be provided. If the drainage of the air wells runs through more than one premises, the size of the conduit drain shall comply with the requirements of the common drain as stipulated in Clause 4.5.1.

### 4.5 **Common Drain**

4.5.1 The internal width of a common drain shall be at least 450 mm.

4.5.2 Where the existing common drain is located within the lot boundary but outside the existing boundary wall or fencing of the development site, the location/position of the existing boundary wall or fencing shall not be altered or realigned. The proposed location of new boundary wall or fencing shall be erected at the same position of the existing boundary wall or fencing. Any deviation to this arrangement shall be approved by the Board.

### 4.6 **Improvements to Existing Drain**

4.6.1 Pursuant to a development proposal, the developer/owner may be required to improve the existing drain such as the outlet drain flowing through the development site, the entrance culvert and the roadside drain.

4.6.2 The size (width and depth) and the alignment of the proposed drain shall be determined and approved by the Board.

### 4.7 **Structure over Roadside Drain/Outlet Drain**

4.7.1 No structure shall be constructed over the roadside drain or outlet drain without the approval of the Board. If approved, the drain under the structure shall be upgraded to the design requirements as determined by the Board.

### 4.8 **Hydraulic & Structural Calculations**

#### 4.8.1 Hydraulic Calculations

For developments of area exceeding 0.4 hectare, the hydraulic calculations for internal drainage system (including the catchment plan), shall be endorsed by a Professional Engineer and submitted to the Board for record.



#### 4.8.2 Structural Calculations

The structural calculations and plans for the following categories of drains shall be endorsed by a Professional Engineer and submitted to the Board for record:

- (a) Drains within the drainage reserve; and
- (b) Closed roadside drains which do not follow the standard designs used by Land Transport Authority.

#### **4.9 Drainage for Underground Facilities**

4.9.1 Basements, tunnels and other underground facilities shall as far as possible be designed to prevent any ingress of storm water. Where ingress of storm water cannot be completely prevented, the catchment contributing to the ingress shall be kept to the minimum and an adequate pumped drainage system shall be provided. The minimum design and operation criteria for the pumped drainage system shall be as follows:

- (a) A pumped drainage system of sufficient size and capacity, as described in Clause 10, shall be provided.
- (b) The catchment of underground facility shall be totally segregated from the surface water catchment. There shall be no direct connection from the internal drain(s)/pumped drainage system within the underground facility to the roadside drain(s)/outlet drain(s). This can be achieved by adopting, but not limited to the following design considerations:
  - (i) Adequate crest levels, as stipulated in Clause 2.2, at the entrances/ access points to the underground facility shall be provided before discharging any surface runoff collected within the development to the roadside drain(s)/outlet drain(s).
  - (ii) Channel runoff from the roofs, rainwater downpipes and all premises at and above ground level into surface gravity drains, but not into the underground structures.
  - (iii) Surface runoff collected within the underground facility shall be discharged to the internal drainage system at the ground level via a swan neck connection which complies with the minimum crest level requirement as stated in Clause 2.2. A typical section of the swan neck connection is shown in Drawing 1.
  - (iv) Provide cut-off drains across the ramps or access ways to prevent surface water from entering underground facilities. Cut-off drains serving the underground structure catchment must not be linked to the surface water drainage system.

#### **4.10 Drainage at Reclaimed Land**

- (a) Proper drainage system, either temporary or permanent, shall be provided at all stages of reclamation works. All proposals of drainage works in connection with reclamation shall be submitted to the Board for approval.
- (b) Before the commencement of any reclamation works, drains affected by the reclamation shall be upgraded and extended to channel off the overland flows from the existing land upstream of the reclamation site.
- (c) All temporary drainage systems provided during the construction stage shall be cleansed and maintained regularly by the reclamation developer/owner to remove all obstructions, silt and rubbish until such time when the reclaimed land is developed and provided with a permanent drainage system.
- (d) The developer/owner shall maintain and manage the completed reclaimed land at all times to ensure that runoff is effectively drained away without causing drainage problems within the land or to the adjacent lots. The finished levels of the completed reclaimed land shall be formed in such a manner to ensure free surface water drainage and no localised ponding. All subsidence, low-lying areas and depressions shall be filled-up and graded to effect proper surface water drainage.

#### **4.11 Outfall Structure for Drain Connecting to the Sea**

All outfall structures shall be extended under and beyond the sand bar area in an encased form and to discharge flow at below the low tide level. Where there is no sand bar formation along the shore, the outfall structure may be in an open or encased form subject to the approval of the Board. In all cases, the outfall shall extend adequately beyond the shoreline such that the sea-bed level is at least 500 mm below the outfall invert at the point of discharge. All outfall structures shall be protected against undermining and scouring effects.

## **5 STRUCTURES WITHIN OR ADJACENT TO DRAIN/DRAINAGE RESERVE**

### **5.1 No Structure Within Drain/Drainage Reserve**

No structure shall be constructed within a drain or drainage reserve.

### **5.2 Drain Connection Within Drainage Reserve**

Drain connection within a drainage reserve shall be closed to maintain the continuity of access along the drainage reserve. The closed drain or the slab and its supporting structure/foundation shall be designed for heavy vehicular loading in accordance with Land Transport Authority's standards.

### **5.3 Embankments and Structures Adjacent to Drain/Drainage Reserve**

All embankments and structures shall be set outside the drainage reserve. They shall be stable and independent of the drainage structures.

The design of embankments and structures near a drain or drainage reserve must not take into consideration the passive resistance offered by the existing or proposed drainage structures. The embankments and structures shall be stable when excavations up to 1.0 m below the invert or proposed invert of the adjacent drain are carried out. In addition, the Qualified Person shall ensure that the embankments and structures can be built without affecting the drainage structures.

#### **5.3.1 Submission of Structural and Stability Calculations for Record**

The structural and stability calculations for an embankment or a structure within 2 m from the edge of the drainage reserve shall be endorsed by a Professional Engineer and submitted to Board for record. The submission of such calculations shall not in any way absolve the Professional Engineer from his/her responsibility.

#### **5.3.2 Drainage for Earth Retaining Structures**

Drainage for earth retaining structures shall not be discharged to the adjacent premises.

##### **(a) Developments at higher ground**

- (i) For new developments, if an earth retaining structure is erected to raise the ground level of the development site above adjacent premises, runoff from the development site, including the sub-soil flow from weepholes of the earth retaining structure (where applicable), shall be drained away by cut-off drains situated along the earth retaining structure or other drainage system as proposed by the Qualified Person within the development site without overflowing into the adjacent premises.
- (ii) In addition, a cut-off drain shall also be provided along the top of the retaining wall to capture the surface runoff from the development and maintenance access shall be provided to facilitate access to the cut-off drains.

- (b) Developments at lower ground
  - (i) If the earth retaining structure is erected at a development site where the ground level is lower than adjacent ground, the earth retaining structure shall not in any way obstruct existing sub-soil and overland flows that are discharging through the development site from the adjacent premises.
  - (ii) The flows shall be drained off by cut-off drains located along the top and bottom of the retaining wall within the development site or other drainage system as proposed by the Qualified Person. These cut-off drains shall be properly connected to an existing roadside/outlet drain and maintenance access shall be provided to facilitate access to the cut-off drains.

#### **5.4 Structure Within/Across Drain/Drainage Reserve**

Where a structure is allowed to be located within a drainage reserve or drain by the Board, the following general technical requirements shall be complied with:

- (a) Drainage Capacity

The affected drain must be hydraulically adequate as determined by the Board, otherwise it must be upgraded to the required size in conjunction with the proposal.

No structure shall be built within the flow channel. Where intermediate support is necessary to be provided within the channel for technical reasons, the reduced discharge capacity must be compensated by suitable enlargement of the channel. Such support, where approved, shall not be located at the centre of the channel or within the dry weather flow channel but at a suitable location where it will cause least obstruction to the flow.

- (b) Structural Integrity

The Board may require the drain affected by the structures to be upgraded in conjunction with the proposal. The proposed structures to be erected within the drain or drainage reserve shall be designed and constructed to be independently supported.

All foundation structures/piers, in the vicinity of or within the drain or drainage reserve shall also be designed and constructed as independent structures from the drainage structures. These foundation structures/piers must be stable when excavations up to 1.0 m below the invert or proposed invert of the affected drain are carried out.

For a proposed structure to be constructed over a drain or drainage reserve, the vertical clearance between the base of the proposed structure and the cope of the existing or proposed drain shall be at least 100 mm.

The independent supports of the proposed structure must be located at minimum distance of 300 mm from the drainage structure(s) or at any other distance as specified by the Board.

(c) Maintenance

The proposed structure to be erected within the drain or drainage reserve shall not inhibit drainage maintenance work. The following provisions for maintenance shall be incorporated:

- (i) For elevated structures (such as Rapid Transit Systems or road viaducts, pedestrian overhead bridges, buildings, etc.) over the drain or drainage reserve:

Sufficient headroom, viz minimum 5.4 m vertical clearance between the base of the proposed elevated structure and the vehicular maintenance access within the drainage reserve, shall be provided. Any deviation shall be approved by the Board.

- (ii) For at-grade structures (such as road decks, pedestrian malls, linkways etc.) over the drain or drainage reserve:

In addition to the provision of gratings and drains as specified in Clause 9.11 and Clause 9.13.4, access openings (4 m by 2 m) with 6 m wide lay-bys shall be provided within the development site but outside the road carriageway or mall. Requirements on the provision for maintenance openings and lay-bys shall be determined and approved by the Board.

(d) Effective Drainage for Proposed Structure

The proposed structure shall be provided with an effective drainage system to intercept and discharge the surface water runoff.

Where a slab is built over a roadside drain to provide access to premises, runoff from the slab shall be effectively drained away without causing drainage problem on top of the slab and the adjacent areas.

## **5.5 Services Within And/or Across Drain/Drainage Reserve**

### **5.5.1 No Services within Drain or Drainage Reserve**

No services, manholes or other services structures shall be laid within a drain or drainage reserve.

Where there is no drainage reserve, services, service manholes or other services structures shall be located at a minimum distance of 300 mm from the drainage structures.

### **5.5.2 Services to Undercross Drain/Drainage Reserve**

Where services are approved to be laid within a drain or drainage reserve, the services shall be laid to undercross the drain/drainage reserve throughout the full width of the drain/drainage reserve with the following minimum clearance below the invert of the existing or proposed drain:

- (a) 1.0 m for lined drain;
- (b) 1.5 m for earth drain or
- (c) Other minimum clearance as may be specified by the Board.

### **5.5.3 Design Loading for Services within Drainage Reserve**

Services located within a drainage reserve, if approved, shall be designed to withstand heavy vehicular loading in accordance with Land Transport Authority's standards and with their own independent supports.

### **5.5.4 Diversion of Services**

Where new drains are to be constructed or existing drains are to be reconstructed, all existing services within or across the drains and drainage reserves shall be re-laid at the cost of the developer/owner to undercross the new or reconstructed drains.

### **5.5.5 Services Ducts in Culverts**

Services ducts may be incorporated in the top slab of the culverts, subject to the approval of the Board.

## 6 REQUIREMENTS FOR CONSTRUCTION ACTIVITIES

### 6.1 General Requirements

- 6.1.1 The execution of any work shall not change, disrupt, fill, block, divert or disturb the existing overland flow or the existing system of drains unless an alternative drainage system has been approved by the Board.
- 6.1.2 The runoff within, upstream of and adjacent to the worksite shall be effectively drained away without causing drainage problems within the worksite or in areas outside the worksite.
- 6.1.3 All earth slopes shall be set outside the drainage reserve.
- 6.1.4 No obstruction of any kind shall be placed, laid or erected within drainage reserves and drains unless authorised by the Board. If so, the drainage reserves and drains shall remain accessible at all times to workers and plant/equipment of, or authorised by the Board.
- 6.1.5 No temporary structures such as cofferdams, crossings, stagings etc. shall be constructed in or over an existing drain without the approval of the Board.
- 6.1.6 Any temporary structure if approved within a drain or drainage reserve shall be removed immediately on completion of the construction works or as directed.
- 6.1.7 Drainage inlets such as drop-inlet chambers and scupper drains shall not be blocked by any material or debris.
- 6.1.8 Drains shall not be covered without the approval of the Board.
- 6.1.9 Bunds of stockpiled materials such as earth from trench work shall not be longer than 10 m and gaps of at least 1 m width shall be provided between the bunds to allow the free flow of surface runoff.
- 6.1.10 Material from any stockpile shall not be allowed to fall or be washed into the drain. Adequate preventive measures, including the provision of proper and stable barricades or screens where necessary, shall be provided.
- 6.1.11 Any damage to existing drain/drainage facilities arising out of any work shall be immediately reported to the Board. Any obstruction to flow arising from the damage shall be immediately and completely cleared. The damaged drain shall be repaired or reinstated to the requirements of the Board.

## **6.2 Laying and Diversion of Services**

No services shall be laid or left (in conjunction with development works) within a drainage reserve. Where the services have to cross a drainage reserve, approval of the Board shall be obtained.

## **6.3 Earth Control Measures (ECM)**

### **6.3.1 Water Quality Parameters to be Complied with**

The discharge from any construction / earthwork sites into storm water drainage system shall not contain Total Suspended Solids (TSS) in concentrations greater than, the prescribed limits under Regulation 4 (1) of the Sewerage and Drainage (Surface Water Drainage) Regulations.

### **6.3.2 ECM Specifications in Tenders**

Developers / owners and Qualified Persons should include the earth control measures (ECM) specifications and schematic or conceptual ECM plans in the tender documents and allow for the cost of ECM in the tenders.

### **6.3.3 Approval to Start Earthworks**

The site operator/contractor shall obtain approval from the Board and implement adequate ECM before the commencement of any earthwork.

### **6.3.4 Submission of ECM Proposal Before Commencement of Works**

The site operator/owner shall submit the detailed ECM proposal, endorsed by a QECP, to the Board to apply for an approval. The ECM proposals (with calculations) shall include a plan (a typical plan is as shown in Drawing No. 8).

### **6.3.5 Design Criteria of ECM**

The ECM shall be designed to cope with at least a storm of return period of 5 years.

### **6.3.6 Installation of ECM on site**

The ECM shall be installed by the site operator/contractor according to the endorsed plans and the completed ECM at site shall be approved by the QECP before commencement of earthworks and construction works.

### **6.3.7 Effective ECM Components**

An effective ECM requires 2 components which shall include, but is not limited to, the following minimum measures in order to meet the legal requirements cited under Regulation 4(1) of the Sewerage and Drainage (Surface Water Drainage) Regulations:

#### **(1) Erosion Control Measures**

The erosion control measures shall minimise the extent and duration of any exposed/bare/erodible surfaces by:

- a. *Proper Work Sequencing* - Proper construction staging and work sequencing shall be adopted to ensure that no large bare/ erodible surfaces are exposed for long duration.



- b. *Covering up of all bare / erodible surfaces* - Bare surfaces (including earth stockpiles) shall be covered by concrete-lining, concrete-paving, milled waste, erosion control blankets, close turfing or other suitable materials. Access roads within the site and at exit/entrance as well as the surfaces around the site facilities (such as office, fabrication and storage yards) shall be covered or paved. Work areas shall be covered with canvas sheets, tarpaulin sheeting or other suitable materials during rain or before work stops every day.

Minimising of the bare erodible surfaces as mentioned above will reduce the volume of silty water to be contained and treated. For areas which have been paved/ covered, the clean surface runoff could be channelled directly into the drains.

- c. *Progressive and timely revegetation and stabilisation* – All bare surfaces shall be restored immediately upon completion of work at every stage.

If a construction site has very little bare/erodible surfaces, the operator/contractor will have less difficulty in containing and treating the silty discharges as described in Clause 6.3.7 (2) below. For those areas within a construction site which have been paved/covered and will not cause silty discharge, it is possible to drain these areas directly into the storm water drainage system without treatment.

(2) Sediment Control Measures

The sediment control measures shall trap, contain and treat the silty discharges from within a construction/earthworks site (including rain, runoff, water from washbay, underground water at basement, etc.) by providing:

- a. *Perimeter Cut-off Drain* – Perimeter cut-off drains shall be concrete-lined and adequate to capture all runoff from the site. For sites located above slope, a boundary wall of at least 600 mm high shall be provided along the entire perimeter of the site to prevent overflow onto adjacent properties.
- b. *Perimeter Silt Fence* – Silt fences shall be erected along the perimeter cut-off drain (between the construction site and perimeter cut-off drain). The silt fence is to be embedded firmly into the ground and made from an approved geotextile filter fabric or equivalents to capture the sediment from stormwater runoff. The sediment built-up behind the silt fence must be regularly removed.
- c. *Intermediate Silt Trap* – Intermediate silt traps of suitable size shall be installed at regular intervals along the perimeter lined cut-off drain. Within the intermediate silt traps, suitable geotextile filter fabric or equivalents shall be installed across the full depth and width and /or coagulation-assistance materials shall be placed. Silt traps relying primarily on hardcore, granite chips or sands for filtration, are not acceptable.
- d. *Holding pond/sump* – All silty runoff shall be collected and channelled to ground holding pond/sump for treatment to the required water quality standard before discharging the runoff into the drain. All silty water shall be treated and discharged within 10 hours after the rainstorm so as to prepare the pond/sump for the next rainfall event.
  - i. No processed/used water, such as slurry water and sillage water shall be discharged to or kept in the holding pond/sump.
  - ii. The holding pond/sump shall be located near the drainage outlet.

- iii. Water level markings shall be provided within the holding pond/sump to indicate the level of water in the holding pond/sump and the depth of the holding pond/sump.
  - iv. The holding pond/sump shall have a storage capacity to cope with a storm of return period of 5 years.
  - v. Cut-off drains could be used as part of the holding pond/sump. The capacity of the cut-off drains available to hold the silty runoff should be clearly tabulated, taking into consideration the site terrain. The wash bay sump shall not be included in the calculation for storage.
- e. Treatment System – Adequately-sized treatment system shall be installed to treat all silty surface runoff before it is discharged into the drains. The treatment system shall be sized to treat and empty the rain runoff water in the holding pond/sump within 10 hours after the rainstorm so as that to prepare the pond/sump for the next rainfall event. Any other water shall be handled separately and shall not be channelled to the holding pond/sump for treatment. The treatment system shall be calibrated regularly according to the manufacturer’s specification. The quality of discharge shall be monitored continuously by a Total Suspended Solids (TSS) meter or by other means.
- i. The treatment plant treats the silty water at a prescribed flow rate and there is no holding capacity within the treatment plant. Treatment plants shall not be included as part of the total holding pond/sump capacity.
  - ii. For above ground holding tank design proposal, contractor shall provide justifications that the system is able to function at all times, in particular, during heavy rain in the middle of the night. The justifications shall include detailed calculations of number of pumps and pump size, provision of redundancy to cater for maintenance and breakdown, positive suction head at the sump pit, provision of power supply for the automated system throughout the entire operation, and configuration of the automated system and the standby manpower as necessary.
  - iii. The above information, schematics and technical drawings shall be clearly enclosed in the ECM plan for contractor to strictly adhere to. Contractor shall engage a QP (mechanical) to design and endorse the pumping system and monitor the performance and revise the ECM design accordingly.
- f. Turbidity Curtains - For works that are within or adjacent to the water bodies, such as canals, rivers, sea or reclamation works, turbidity curtain(s) shall be installed along all the exposed slopes/riverbanks. The silt within the turbidity curtain(s) shall be removed regularly and disposed off accordingly to the relevant regulations.
- g. Wheel wash – Used water from wheel wash shall not be discharged directly to the drain. The silty water within the wash bay could be channelled into the holding pond/ sump.
- h. Minimal or No Discharge - Recycling of water should be practised at construction/earthwork sites. The recycled water could be used for non-potable purposes in order to minimize discharge into the drain.

### **6.3.8 Inspection & Review of ECM during Contract duration**

The site operator/contractor shall inspect the conditions of the ECM regularly and during/after every rain event.

The site operator/contractor shall arrange for his QECP to carry out regular audit/review for every stage of the earthworks and construction works, and also revise/amend the ECM at site according to the advice of the QECP. All inspection/audit/review reports shall be kept on site and made available to the Board upon request.

### **6.3.9 Maintenance of ECM during Contract Duration**

The ECM implemented on site shall be checked and maintained regularly to ensure that the ECM remains effective throughout the whole duration of works. This shall include:

- i. Replacing of silt fences and erosion control blankets
- ii. Re-paving of worn-out concrete surfaces
- iii. Replacing of membrane modules
- iv. Calibration of silty water treatment plant according to the manufacturer's specification
- v. Removal of silt accumulated in the holding sump
- vi. Removal of silt accumulated at the silt fence and beside the boundary wall

### **6.3.10 Monitoring of Discharge during Contract duration**

The site operator/contractor shall monitor the discharge water quality as cited in Clause 6.3.1 before it enters the roadside/ outlet drain(s).

The site operator/contractor shall for this purpose, provide a continuous monitoring system which include the necessary monitoring instrument and CCTV system upon requested by the Board. The CCTV system shall be positioned at the drain so that it is able to view the discharge outlet(s) along with the upstream of the drain clearly. The CCTV image quality shall be able to distinguish the clear water and the silty water clearly.

The site operator/contractor shall keep the CCTV in operations at all times.

The site operator/contractor shall submit regular reports (including photographic and monitoring records) of the site ECM as well as those for discharge quality upon requested by the Board.

### **6.3.11 Removal upon Completion**

The ECM shall not be removed before the completion of work. The site operator/ owner shall inform the Board prior to removal of the ECM on completion of the project.

## **6.4 Earthworks**

- (a) The approval of the Board shall be sought for all earthworks affecting the existing drainage system or the flow pattern of surface runoff. In the event that earthworks are to be carried out adjacent to major drains and canals, the developer/owner shall engage a Qualified Person to carry out soil investigation works and slope stability analysis to ensure that the earthworks will not cause any damage to the drainage structures.
- (b) The developer/ owner shall take all necessary steps and measures, such as implementing suitable soil stabilisation methods and temporary protection works to ensure the stability and structural integrity of the existing drainage structures.
- (c) Earth control measures shall be provided in accordance with the requirements as stipulated in Clause 6.3.

## **6.5 Road Works**

A temporary drainage system shall be provided for all roadworks to prevent flooding or water ponding on the road. Where the road is being raised and the new road drainage outlets are at a higher level than the existing ones, the existing outlets shall not be blocked unless temporary alternative drainage system has been provided. The developer/owner and the Qualified Person shall be responsible for implementing all necessary measures to ensure that the site is kept flood free at all times. Where necessary, the Board may require the submission of hydraulic calculations, programme of works, temporary drainage arrangements at various stages of the roadworks, etc. by the Qualified Person.

## **6.6 Reclamation Works**

- 6.6.1 All reclamation works shall be carried out in accordance with Clause 2.3 and 4.10.
- 6.6.2 During reclamation, a temporary drainage system including perimeter cut-off drains, silt-traps, silt fences and outlet connections shall be provided. The temporary drainage system shall include erosion protection linings, such as concrete, geotextile mattress and other suitable materials to be approved by the Board. The proposals of the temporary drainage system shall be submitted to the Board for approval.
- 6.6.3 The temporary drainage system shall be cleansed and maintained regularly by the reclamation agency to remove all obstructions, silt and rubbish during the reclamation period.

# **CODE OF PRACTICE ON SURFACE WATER DRAINAGE**

## **PART II**

### **DESIGN REQUIREMENTS**

- 7 Drainage Design And Considerations
- 8 Integration of Adjacent Watercourses With Developments and ABC Waters Design Features Within Developments
- 9 Drainage Structures and Facilities
- 10 Pumped Drainage System

# CODE OF PRACTICE ON SURFACE WATER DRAINAGE

## PART II

### DESIGN REQUIREMENTS

#### 7 DRAINAGE DESIGN AND CONSIDERATIONS

##### 7.1 Computation of Peak Runoff

###### 7.1.1 Rational Formula

The Rational Formula shall be used to compute the peak runoff:

$$Q_r = \frac{1}{360} CIA$$

where  $Q_r$  = peak runoff at the point of design ( $m^3/s$ )

$C$  = runoff coefficient

$I$  = average rainfall intensity (mm/hr)

$A$  = catchment area (hectares)

###### 7.1.2 Runoff Coefficient

The runoff coefficient ( $C$ ) depends on the degree and type of development within the catchment. Catchments are classified according to the expected general characteristics when fully developed. The  $C$  values are as follows:

Characteristics of catchment when fully developed	Value of C
Roads, highways, airport runways, paved up areas	1.00
Urban areas fully and closely built up	0.90
Residential/industrial areas densely built up	0.80
Residential/industrial areas not densely built up	0.65
Rural areas with fish ponds and vegetable gardens	0.45
Note: For catchments with composite land use or surface characteristics, a weighted value of $C$ may be adopted.	

### 7.1.3 Rainfall Intensity

For a storm of return period (T) years, the rainfall intensity (I) is the average rate of rainfall from such a storm having a duration equal to the time of concentration (tc). The rainfall intensity (I) can be obtained from the Intensity-Duration-Frequency (IDF) curves by estimating the duration of rainfall (equals to the time of concentration, tc) and selecting the required return period of (T) years. The Intensity-Duration-Frequency (IDF) curves for Singapore Island are shown in Appendix 4.

The return periods (T) adopted for the design of drainage systems in Singapore shall be as follows and may be subjected to any other specific requirement imposed by the Board:

Area Served by Drainage System	Return Period (T)
Catchment of less than 100 ha	10 years
Catchment of 100 to 1000 ha	25 years
Catchment of more than 1000 ha	50 years
Airport runway or any area as specified by the Board	100 years

### 7.1.4 Time of Concentration

The peak runoff (Qr) occurs at the point of design when all parts of the catchment receiving a steady, uniform rainfall intensity are contributing to the outflow at this point. This condition is met when the duration of rainfall equals the time of concentration (tc). The time of concentration (tc) consists of the overland flow time (to) plus the drain flow time from the most remote drainage inlet to the point of design (td), viz.  $tc = to + td$ .

The overland flow time (to) varies from 5 minutes to 15 minutes, depending on the overland travel distance, land topography and characteristics. The drain flow time (td) shall be estimated from the hydraulic properties of the drainage channel.

### 7.1.5 Maximum Allowable Peak Runoff

The following types of developments are required to control the peak runoff discharged from the affected development sites:

- (a) New erection and reconstruction works to all developments greater than or equal to 0.2 hectares in size; and
- (b) Additions & Alterations (A&A) works to all existing developments where affected area is greater than or equal to 0.2 hectares in size such as:
  - (i) Addition of new building(s); or
  - (ii) Extension to existing building(s); or
  - (iii) Partial reconstruction of existing building(s);
  - (iv) Any combination of the above

The maximum allowable peak runoff to be discharged to the drains will be calculated based on a runoff coefficient of 0.55, and for design storms with a return period of 10 years and for various storm durations of up to 4 hours (inclusive). Peak runoff reduction can be achieved through the implementation of ABC Waters design features and/or structural detention and retention features, such as:

- (i) Detention tanks/drains;
- (ii) Retention/sedimentation ponds;
- (iii) Wetlands;
- (iv) Bioretention swales;
- (v) Bioretention basins or rain gardens;
- (vi) Porous pavements, etc.

Details (calculations and/or hydraulic model results) showing how the proposed system meets the required peak runoff rates shall be submitted and endorsed by PE (Civil). For systems that include ABC Waters design features to meet the required peak runoff rates, the details must be endorsed by an ABC Waters Professional, who is also a PE (Civil).

For design guidance on detention tank systems, QPs can refer to the Technical Guide for On-site Stormwater Detention Tank Systems, available on the PUB website.

For design guidance on the ABC Waters design features, QPs can refer to the ABC Waters Guidelines and relevant chapters in the Engineering Procedures, available on the PUB website. Due consideration shall be given to meeting ABC Waters storm water quality objectives, which will often require treatment of storm water runoff using ABC Waters design features.



## 7.2 Computation of Discharge Capacity

### 7.2.1 Steady Uniform Flow Condition

Drains are designed for steady uniform flow conditions and one-dimensional method of analysis is used.

### 7.2.2 Manning's Formula

Drains shall be designed to have discharge capacities ( $Q_c$ ) adequate to cope with the estimated peak runoffs ( $Q_r$ ). The size, geometry and the bed gradient of a drain determine its discharge capacity ( $Q_c$ ). With the required discharge capacity ( $Q_c$ ) determined [which must be equal to or larger than the peak runoff ( $Q_r$ )], the size of the drain is computed from the Manning's Formula:

$$Q_c = \frac{1}{n} AR^{\frac{2}{3}} S^{\frac{1}{2}}$$

where  $Q_c$  = discharge capacity of drain ( $m^3/s$ )  
 $n$  = roughness coefficient  
 $A$  = flow area ( $m^2$ )  
 $P$  = wetted perimeter (m)  
 $R$  =  $A/P$  = hydraulic radius (m)  
 $S$  = bed gradient

### 7.2.3 Roughness Coefficient

The value of the roughness coefficient ( $n$ ) depends on the drain's flow surface and is given below:

Boundary Condition	Roughness Coefficient (n)
Unplasticised Polyvinyl Chloride(UPVC)	0.0125
Concrete	0.0150
Brick	0.0170
Earth	0.0270
Earth with stones and weed	0.0350
Gravel	0.0300

Note: Where there are different flow surfaces within a drain section, equivalent roughness coefficient may be used.

### 7.3 Design Considerations

#### 7.3.1 Minimum Velocity and Dry Weather Flow

The velocity of flow in a drain shall not be lower than 1.0 m/s for self-cleansing action to take place. However, the flow rate during dry weather may fall to a low level where this minimum velocity cannot be achieved. The problem can be solved by introducing a small channel in the drain to confine the dry weather flow to a smaller flow section. The dimensions of such a dry weather flow channel is given below or unless otherwise stated by the Board. The design of Type C3 channel is as shown in Drawing No. 1.

Top Width of the drain (W)	Bottom Width of dry weather flow (D.W.F)	Depth of D.W.F
$W \leq 3.0\text{m}$	C3	
$3.0\text{m} < W \leq 4.5\text{m}$	0.6m	0.15m
$4.5\text{m} < W \leq 6.0\text{m}$	0.9m	0.15m
$6.0\text{m} < W \leq 9.0\text{m}$	1.2m	0.20m
$9.0\text{m} < W \leq 12.0\text{m}$	1.8m	0.25m
$W > 12.0\text{m}$	2.1m	0.30m

#### 7.3.2 Maximum Velocity

The velocity of flow in a drain shall not be too great to cause excessive scouring or hydraulic jumps. Hence the velocity of flow in a concrete-lined drain shall be limited to a maximum of 3.0 m/s or below the critical velocity, whichever is lower. For an earth stream, the maximum velocity shall be limited to 1.5 m/s. Further limitation of the maximum velocity shall be complied with when specified by the Board.

#### 7.3.3 Sub-critical Flow

Drains are designed to carry sub-critical flows. Critical state of flow exists when the Froude Number is equal to one. An open channel flow at or near the critical state shall be avoided as under such a condition the water surface is unstable and wavy. In order to secure greater flow efficiency, channel flow shall be designed so that the Froude Number shall fall within the range from 0.8 decreasing to such minimum value as to achieve a practical flow depth and permissible flow velocity.

#### 7.3.4 Freeboard

Freeboard refers to the depth from the top of the drain (cope/bank) to the top of the water surface in the drain at design flow condition. Sufficient freeboard shall be provided to prevent waves or fluctuation of the water surface from overflowing the cope/bank. Generally, a depth of freeboard equivalent to 15% of the depth of the drain is required.

## **8 INTEGRATION OF ADJACENT WATERCOURSES WITH DEVELOPMENTS AND ABC WATERS DESIGN FEATURES WITHIN DEVELOPMENTS**

### **8.1 Integration of Adjacent Watercourses with Developments**

- 8.1.1 As part of the Active, Beautiful, Clean Waters (ABC Waters) Programme, integration of adjacent watercourses with proposed developments is encouraged, whilst satisfying the engineering requirements for drainage functions without posing any public safety, maintenance or environmental problems. These include, but are not limited to:
- (a) Enhancing the accessibility or connectivity to waterbodies/waterways, eg. creating community spaces for adjacent to watercourses and providing boardwalks to bring people closer to water, etc.;
  - (b) Providing aesthetic treatment to waterways, eg. use of a more natural finish such as block pitching or imprints on canal walls, planting along the canal walls, etc.;
  - (c) Installing ABC Waters Design features to detain and treat storm water runoff closer to the source (see Clause 8.2 for further details).
- 8.1.2 The designs of the aesthetic waterbodies, waterways and safety barriers need not be constrained by the standard features as shown in this Code of Practice as long as these facilities fulfill the drainage requirements and do not give rise to any public safety, maintenance or environmental problems.
- 8.1.3 The approval of the competent planning authorities shall also be sought for all such proposals. Where appropriate, the aesthetic waterbodies and watercourses shall be integrated into the development proposals and be maintained by the developers/owners of these developments.

### **8.2 Integration of ABC Waters Design Features within Developments**

- 8.2.1 Qualified Persons together with the developer/owner are strongly encouraged to enhance the development by adopting appropriate ABC Waters design features as described in the latest version of “ABC Waters Design Guidelines” and “Engineering Procedures for ABC Waters design features” published by the Board (available at <https://www.pub.gov.sg/abcwaters/designguidelines>). These guidelines were developed based on the following principles:
- (a) Reduction of runoff and peak flow from the development site by implementing local ABC Waters design features that provide detention measures and minimise impervious areas;
  - (b) Improvement of quality of water draining from the development into receiving environment. For example, through effective filtration and retention measures via ABC Waters design features, runoff from the site can be treated to remove pollutants and silt, thereby protecting the water quality in waterways downstream;
  - (c) Integration of stormwater treatment into the landscape by incorporating multiple-use ABC Waters design features that also maximise the aesthetics and recreational amenities of developments; and
  - (d) Protection and enhancement of natural water systems within the development site.

- 8.2.2 The developer/ owner shall engage an ABC Waters (Active, Beautiful, Clean Waters) Professional to plan, design, oversee the construction of, and develop a maintenance plan for the ABC Waters design features.

For developments of area exceeding 0.4 hectares, DC submissions for ABC Waters design features, comprising the following items, should be submitted to the Board as part of DC submission:

- (a) Hydraulic calculations for the ABC Waters design features, endorsed by an ABC Waters Professional who is a PE (Civil). The calculation shall be accompanied by completed relevant design templates in Excel format, available on the PUB website.
- (b) Catchment/location plan of ABC Waters design features endorsed by an ABC Waters Professional who is an Accredited Landscape Architect or a registered Professional Architect.
- (c) Design drawings and maintenance checklists endorsed by an ABC Waters Professional of any profession.

If there is any change to the catchment or design of the ABC Waters design features subsequent to DC approval, QP shall submit a DC amendment with the full set of updated items (a), (b) and (c) above with respective endorsement and a summary table for all the amendments..

- 8.2.3 For ABC Waters design features that are designed to be part of the measures to comply with Clause 7.1.5, the developer/owner shall maintain the ABC Waters design features regularly to ensure that these features are well maintained and remain effective in serving the functions as stipulated in Clause 7.1.5.

## **9 DRAINAGE STRUCTURES AND FACILITIES**

### **9.1 Drain and Culvert**

- 9.1.1 All U-shaped drains and box culverts shall be designed to be hydraulically adequate, structural sound and geotechnically stable in accordance with the current codes, specifications and requirements.
- 9.1.2 All roadside drains shall be constructed in accordance with the standard Land Transport Authority's specifications shown in Drawing No. 1 or such other drawings to be issued by Land Transport Authority or the Board. The roadside drains shall be provided with false bottom as may be required by the Board.

### **9.2 Transition**

A transition is required where there is a change of drain cross-section. The purpose of a transition is to change the shape of flow and surface profile in such a manner that minimum energy losses occur and cross waves and other turbulence are reduced. This may be achieved using tapering walls with no sudden changes of cross-section. The minimum length of a transition shall be 1.5 times the width of the wider drain section.

### **9.3 Curves and Bends**

- 9.3.1 The presence of curves or bends in drain alignment is sometimes unavoidable. Difficulties in design often arise because of the complexity of the flow around a curved path. A drain curve will increase frictional loss and lead to the danger of serious local erosion due to spiral flow. Hence, the radius of any horizontal curve shall be as large as possible, consistent with the general terrain, in order to reduce the super elevation of the water surface and preserve the freeboard. A horizontal curve shall have a minimum radius of 3 times the width of the drain channel.
- 9.3.2 The benching of the drain at the bend shall be configured to minimise sedimentation at the inner side of the bend. For this purpose, the dry weather flow channel at the bend shall be aligned towards the outer side of the bend, with the centre of the channel spaced at a quarter of the drain width from the outer cope of the drain.

### **9.4 Sump for Drain Intersections**

A sump of sufficient size shall be provided where drains converge. The minimum internal width of the sump shall not be less than 1.5 times the width of the drain leading away from the sump. Drains connecting into the sump shall not form an acute angle with the outgoing drain flow and shall connect at different levels wherever possible. The invert level of the downstream drain shall be lower than the invert level of the sump so that no stagnant water will collect in the sump.

### **9.5 Drain Connection to Existing Drain**

Drain connection shall not join an existing drain at an angle that is against its flow. Invert level of the drain connection shall be as high as hydraulically possible and must not be lower than the benching level of the drain receiving the flow.

## **9.6 Maintenance Access for Drainage Reserve**

- 9.6.1 The maintenance access within a drainage reserve shall be level and continuous. The requirements of the levelled maintenance access are shown in Drawing No. 3. If there is an approved structure overcrossing a drainage reserve, ramps (not steeper than 12%) shall be provided at both sides of the structure for the continuity of maintenance access.
- 9.6.2 Access from adjacent road to drainage reserve shall be provided. At the entrance of the access, detachable bollards or posts and chains shall be provided as shown in Drawing No. 4.

## **9.7 Markers along Edge of Drainage Reserve**

If a drainage reserve is not fenced-out from the adjoining premises, concrete markers shown in Drawing No. 4 shall be installed at maximum 50 m spacings along the edge(s) of the drainage reserve to demarcate the drainage reserve line(s). Closer spacing may be necessary at curves/bends.

## **9.8 Drop-inlet Chambers, Inlet Openings and Slot-Outlets**

- 9.8.1 Runoff from road carriageways (including viaducts) and carparks shall be effectively drained away to prevent water stagnation and to ensure road safety. Drop-inlet chambers and concealed scupper drainage shall be designed in accordance with the Land Transport Authority's latest Standard Details of Road Elements and shall be provided at maximum 6 m spacings along all road carriageways. Intermediate sump shall be provided if the length of the concealed scupper drainage exceeds 6m. For curves and bends, inlet openings shall be provided at every 3m interval.

For flood prone areas, hotspots or any other areas as specified by the Board, enhanced drop-inlet chambers (shown in Drawing No. 5) shall be provided.

- 9.8.2 At all T-junctions of roads with one or more of the connecting side roads sloping down towards the junction, drop-inlet chambers shall be provided at every 3m or alternatively, slot-outlets as specified in Land Transport Authority's latest Standard Details of Road Elements shall be provided. Slot-outlets may also be used where an existing roadside drain is less than 500 mm deep or at areas outside the road carriageways such as carparks.
- 9.8.3 The size of openings and discharge pipe into the storm water drainage system has to be at least 250 mm diameter. The discharge pipe that is constructed has to avoid 90 degree bend for discharge towards downstream.

## **9.9 Safety Railings**

Standard safety railings shall be provided for all open drains more than 1.0 m deep. "Type A" railings as specified in Land Transport Authority's latest Standard Details of Road Elements shall be installed for new open drains. Otherwise, railings as specified in Drawing No.6, to match the existing railings on site, shall be installed when requested by the Board.

## **9.10 Rungs in Drains**

Non skid aluminium rungs shall be provided at every opening/grating for closed drains with internal depth equal to or greater than 0.9m. Rungs shall be embedded in the drain wall as shown in Drawing No. 1.

## 9.11 Grating over Closed Drain/Culvert

- 9.11.1 All gratings provided over closed drains/culverts shall be hinged to fixed frames securely embedded into the drain structures. Mild steel heavy duty gratings shall be used for closed drains subjected to vehicular loadings, whereas light duty gratings shall only be used for pedestrian loadings. The gratings, frames and chequered plates shall be galvanized. The details of the gratings and chequered plates shall be designed in accordance with the Land Transport Authority's latest Standard Details of Road Elements.
- 9.11.2 For drains with internal width greater than 4m, access opening (4m x 2m) shall be provided as shown in Drawing No. 2.
- 9.11.3 Where a culvert runs across the road, no sump/grating shall be sited on the road carriageway. Where necessary, sumps with galvanised mild steel gratings shall be provided at the two side-tables of the road. In the case of a dual carriageway, a sump with galvanised heavy duty mild steel grating shall be provided at the centre divider.
- 9.11.4 The size and spacing of gratings required shall be based on the internal width of the closed drain, as follows:

Internal Width (W)	Grating	
	Size	Spacing
W > 4 m	850 mm x 1000 mm	50 m (staggered)
	in addition 4 m x 2 m (opening)	500 m
2 m < W ≤ 4 m	850 mm x 1000 mm	50 m (staggered)
	in addition 1.5 m x 1.5 m (opening)	500 m
750 mm < W ≤ 2 m	850 mm x 1000 mm	6 m (for drain ≤ 1 m deep) or 18 m (for drain > 1 m deep)
W ≤ 750 mm	700 mm x 850 mm*	6 m
<p>Note: (i) Rungs shall be embedded at the drain wall at every opening/grating for closed drains with internal depth equal to or greater than 0.9m in accordance with Clause 9.10.</p> <p>(ii) For drain or drainage reserve within the development site, maintenance opening shall comply with the requirements specified in Clause 5.4c.</p> <p>* Subject to approval of the Board, if the minimum size of closed drain as specific in Clause 4.3.1 cannot be met, the details of the Grating may be designed in accordance with the drawing as shown in Drawing No. 7A or 7B</p>		

- 9.11.5 Where a closed drain exceeds 3 m deep, access shaft (2 m by 1.5 m) may be required by the Board. If the access shaft is deeper than 4 m, intermediate platform shall be provided as shown in Drawing No. 3.

## **9.12 Entrance Culvert/Crossing**

- 9.12.1 Where an entrance culvert/crossing is proposed at a stretch of closed drain, gratings/ openings shall be provided at the closed drain sections upstream and downstream of the proposed entrance culvert/ crossing. The gratings shall be designed in accordance with the Land Transport Authority's latest Standard Details of Road Elements.
- 9.12.2 Under the exceptional circumstance where the entrance culvert/crossing is shallower than 600 mm or when requested by the Board, one number of hinged open gratings as per Drawing no. 7C shall be installed in the middle of the entrance culvert/crossing.

## **9.13 Live Loads on Drains**

- 9.13.1 In the design of drains, stability of the slope and upheaval shall be considered. A nominal live load surcharge of 10 kN/m<sup>2</sup> shall be taken into consideration in the design of drains except as qualified by Clause 9.13.2 and Clause 9.13.4.
- 9.13.2 For drains that are adjacent to roads and are affected by vehicular loading, a live load surcharge of 20 kN/m<sup>2</sup> shall be taken into consideration in the design of drains.
- 9.13.3 Culverts carrying vehicular loading shall be designed to withstand bridge loading in accordance with Land Transport Authority's standards.
- 9.13.4 For drains that are required to install 4 m x 2 m grating as stipulated in Clause 5.4.cii, the drains shall be designed to withstand bridge loading in accordance with Land Transport Authority's standards.



**10 PUMPED DRAINAGE SYSTEM**

10.1 The minimum design and operation criteria for the pumped drainage system shall be as follows:

- (a) The pumping capacity shall be adequate to cater for immediate discharge of the storm water ingress of not less than 150 millimetres per hour from the entire source catchment area; i.e.:

$$P > \frac{IA}{3.6 \times 10^6}$$

where P = pumping capacity (m<sup>3</sup>/s)

I = rainfall intensity (mm/hr)

A = catchment area contributing to ingress of storm water (m<sup>2</sup>)

- (b) There shall be minimally one complete set of back-up pumping equipment, including back-up pumps and pumping mains. The pumped drainage system shall be supported by a generator should the main power supply fail.
- (c) The pumping installation shall be designed with an automated device to start the pumping operation at times of storm water ingress, with operational option for manual control to override the automated device whenever desired.
- (d) Adequate pump sump shall be provided with sufficient storage capacity to cater for the total quantum of inflow from the entire source catchment area over a duration of at least 3 hours or such longer period as may be deemed necessary by the Qualified Person or as required by the Board for the re-activation of the pumping installation in the event of emergency breakdown/repairs or power failure, based on the maximum recorded rainfall given below:

<b>Duration (hrs)</b>	3	4	5	6	12	24
<b>Total Rainfall (mm)</b>	196.9	210.6	253.4	281.9	376.7	533.2

- (e) The Qualified Person shall formulate and implement a well-regulated procedure for the maintenance, operation and monitoring of the pumped drainage system.
- (f) The base of the pump sump shall be designed with a gradient of 1:40 or steeper, and which shall be graded towards the pumps. The pumps shall be located within a small sump pit which should be deeper than the pump sump so that there will be no stagnant water in the pump sump at all times.

**10.2** The criteria specified above are minimum requirements which shall be complied with. Nevertheless, the Qualified Person shall be fully responsible for the complete design of the pumped drainage system, incorporating such additional features or requirements as the Qualified Person may deem necessary to achieve reliable protection of the basements, tunnels or underground facilities against flood.

- 10.3** The civil and structural components of the pumped drainage system (including basement and/or detention tank pump systems) shall be designed and endorsed by a Professional Engineer (Civil) while the mechanical and electrical components shall be designed and endorsed by a Professional Engineer (Mechanical/Electrical). Design computations duly endorsed by the Professional Engineers shall be submitted to the Board for record, including the operation sequence and monitoring measures of the pumped drainage system and other relevant information.
- 10.4** The developer/owner shall be responsible for the maintenance, operation and monitoring of the pumped drainage system. The Qualified Persons shall liaise with the developer/owner to ensure that a well-established management set-up is operational to undertake this function before applying for the issue of Temporary Occupation Permit and Certificate of Statutory Completion.
- 10.5** The Board may in special cases introduce amendments or additional requirements for the design and operation of the pumped drainage systems.

## **CODE OF PRACTICE ON SURFACE WATER DRAINAGE**

### **PART III**

#### **ENSURING THE INTEGRITY OF STORM WATER DRAINAGE SYSTEMS**

- 11 Temporary Occupation Permit (TOP)
- 12 Certificate of Statutory Completion (CSC)
- 13 Maintaining the Integrity of Storm Water Drainage Systems including Flood Protection Measures

# CODE OF PRACTICE ON SURFACE WATER DRAINAGE

## PART III

### ENSURING THE INTEGRITY OF STORM WATER DRAINAGE SYSTEMS

#### 11 TEMPORARY OCCUPATION PERMIT (TOP)

##### 11.1 Compliance during Temporary Occupation Permit (TOP)

11.1.1 QPs are required to declare that their platform, crest levels and maximum allowable peak runoff from the development are in compliance with the Code of Practice on Surface Water Drainage and constructed in accordance with approved plans when applying for Temporary Occupation Permit (TOP) clearance.

11.1.2 The declaration shall consist of the application for TOP clearance and be supported by as-constructed survey plans indicating:

- (i) the crest levels, platform levels (based on the approved flood protection measures);
- (ii) pump drainage system for basement;
- (iii) structural detention and retention features and/or ABC Waters design features, if they are used to satisfy the detention requirement as stipulated in Clause 7.1.5; and
- (iv) any other relevant information as required by the Board

prepared and endorsed by a Registered Surveyor.

Submission requirements for “As- Constructed” drawings for structural detention and retention features and/or ABC Waters design features are shown in Appendix 5.

11.1.3 The Board will only issue TOP clearance to the developer/ owner when the declaration and all necessary supporting documents are submitted and assessed to be in compliance with the requirements of approved plans and the Code of Practice on Surface Water Drainage.

## **12 CERTIFICATE OF STATUTORY COMPLETION (CSC)**

### **12.1 Drainage Works According to Approved Plan**

Drainage works shall be constructed in accordance with the approved drainage plans, the Sewerage and Drainage Act (Chapter 294), the Sewerage and Drainage (Surface Water Drainage) Regulations and this Code of Practice on Surface Water Drainage.

### **12.2 Supervision**

- (a) The Qualified Person shall comply with the relevant sections of the Sewerage and Drainage Act (Chapter 294).
- (b) The Qualified Person shall be fully responsible for the supervision and construction of drainage works based on the approved plan.
- (c) The Qualified Person shall notify the Board of any proposed deviation of works from the approved plan and obtain approval for the deviation by submitting drawings showing the amendments before proceeding with the works.
- (d) The Qualified Person shall, if necessary, notify/apply directly to all the relevant authorities such as the Land Transport Authority (LTA), National Parks Board (NParks) and National Environmental Agency (NEA) before carrying out drainage works and shall abide by the conditions stipulated by the relevant authorities.

### **12.3 Completion of Works**

On completion of drainage works/facilities, the Qualified Person shall certify and submit to the Board a Certificate of Inspection for Drainage Works.

### **12.4 “As-Constructed” Drainage Drawing and Piling Record**

On completion of drainage works/facilities, the Qualified Person shall submit the “As-constructed” drawings and piling records to the Board for record. “As-constructed” drawings for the following categories of drainage works/facilities need to be submitted:

- (i) Drains and approved structures within drainage reserve
- (ii) Roadside drains

Submission requirements for “As- Constructed” drainage drawings are shown in Appendix 5.

### **12.5 Survey Plan**

A survey plan shall be submitted if a development or structure is constructed within less than 300 mm from a drainage reserve. The survey plan shall consist of a site plan and cross-sections showing the development or structure and lot boundary in relation to the drainage reserve. The survey plan shall be prepared and endorsed by a Registered Surveyor.

## **12.6 Defects Liability Period**

Drainage works to be handed-over to the Board shall have a one year Defects Liability Period. The Defects Liability Period shall commence from the date the Board gives no objection to the issue of the CSC. The developer/owner shall pay for the cost of rectification of defects in the drainage works during the Defects Liability Period.

## **12.7 Handing-over of Drain**

Upon the expiry of the Defects Liability Period, the Qualified Person shall arrange for the handing-over of the drainage works to the Board after all the necessary or required rectification works are satisfactorily completed.

**13 MAINTAINING THE INTEGRITY OF THE STORM WATER DRAINAGE SYSTEMS INCLUDING FLOOD PROTECTION MEASURES**

**13.1 Responsibility of Developer/Owner/Managing Agent/MCST/Town Council**

The Developer/Owner/Managing Agent/MCST/Town Council shall be responsible for the maintenance, operation and monitoring of the storm water drainage systems within their premises. These include, but are not limited to, regular adequacy checks on the flood protection measures such as minimum crest levels, detention/retention pond systems and pumped drainage system.

**13.2 Declaration on Storm Water Drainage Systems**

13.2.1 Upon obtaining the Temporary Occupation Permit (TOP), the Developer/ Owner/ Managing Agent/ MCST/ Town Council shall make annual declarations and submissions for the following storm water drainage systems via PUB website-Qualified Persons Portal:

- i. For developments installed with automated flood protection devices, a certificate of inspection of the automated flood protection device endorsed by a PE (Civil or Mechanical) together with supporting documents such as on-site leak test report and photographs shall be submitted. The inspection shall make reference to any relevant international standards or any requirements specified by the Board.
- ii. For developments constructed with pumped detention tanks for detention function as stipulated in Clause 7.1.5, the following documents shall be submitted:
  - (a) Annual electrical installation license issued by EMA;
  - (b) Quarterly maintenance records of pumps;
  - (c) Quarterly maintenance records of level control system; and
  - (d) Quarterly cleaning and desilting records of tank and pump sump.

13.2.2 The Developer/Owner/Managing Agent/MCST/Town Council shall submit amendments to the standard operating procedure (SOP) of the flood protection measures endorsed by a PE (Civil and/or Mechanical) to the Board for record.

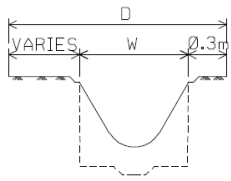
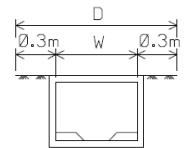
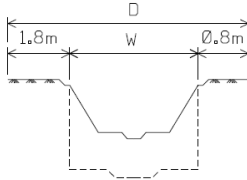
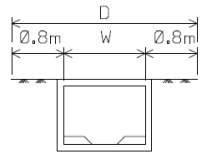
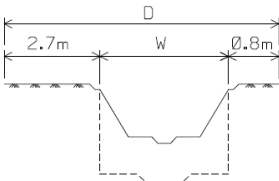
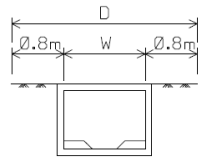
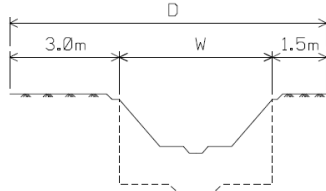
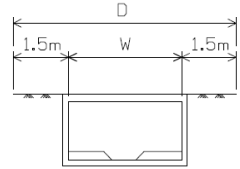
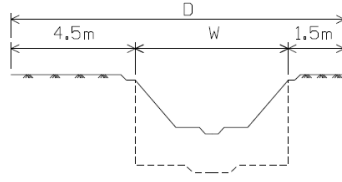
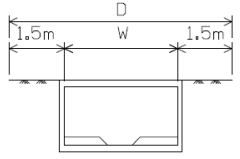
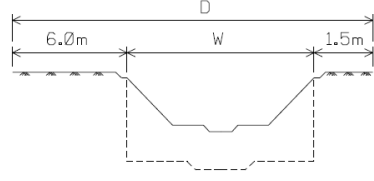
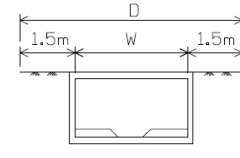
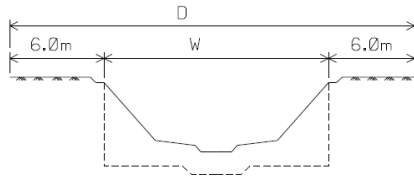
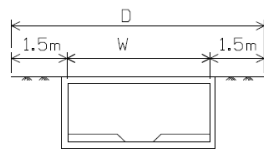
DRAINAGE RESERVE REQUIREMENTS				
INTERNAL WIDTH OF DRAIN W	TYPICAL CROSS-SECTION		MINIMUM DRAINAGE RESERVE D	
			FOR OPEN DRAIN	FOR CLOSED DRAIN
1.0m TO 1.2m			3.0m	W+0.6m
>1.2m TO 3.0m			W+2.6m	W+1.6m
>3.0m TO 4.5m			W+3.5m	W+1.6m
>4.5m TO 6.0m			W+4.5m	W+3.0m
>6.0m TO 9.0m			W+6.0m	W+3.0m
>9.0m TO 25.0m			W+7.5m	W+3.0m
> 25.0m			W+12.0m	W+3.0m

 CLOSE TURVING (SEE DRAWING NO.3 FOR DETAILS.)



**SUBMISSION REQUIREMENTS FOR FLOOD PROTECTION MEASURES****1) During Development Control (DC) stage**

For all developments with flood protection measures, the following documents, endorsed by a Qualified Person, shall be submitted:

- (i) Proposed plans indicating the crest levels and/or platform level with and without flood barrier at various entrance and exit points;

**2) During Detailed Plan (DP) stage**

For developments where flood barriers are automated and/or with more than 2 points of entry/ exit, or when requested by the Board, the following shall be submitted:

- (i) Proposed size, type and design of the flood barrier.
- (ii) Details on the standard operating procedure (SOP) including the proposed maintenance plan of the flood barrier to be endorsed by a PE (Civil and/or Mechanical), and the developer/ owner.

**3) During Temporary Occupation Period (TOP) stage**

For all developments with flood protection measures, the following documents, endorsed by a Registered Surveyor, shall be submitted together with the declaration that their platform and crest levels are in compliance with the Code of Practice on Surface Water Drainage and constructed according to approved plans:

- (i) As-constructed survey plans indicating the crest levels, platform levels and the flood protection levels (based on the approved flood protection measures).

**4) Certificate of Statutory Completion (CSC) stage**

For developments where automated flood barriers are implemented, the following documents, endorsed by a PE (Civil and/or Mechanical), shall be submitted:

- (i) Leak Test Certification on the installed flood barrier, in compliance with relevant international standards or any requirements specified by the Board.

**5) Maintaining the integrity of Storm Water Drainage System**

Upon obtaining Temporary Occupation Permit (TOP), the Developer/Owner/Managing Agent/MCST/Town Council shall make annual declarations and submissions that the inspections to storm water drainage system as stipulated in Clause 13.2 have been carried out.

**PRINCIPLES AND STANDARDS FOR FLOOD PROTECTION OF UNDERGROUND RAPID TRANSIT SYSTEMS, VEHICULAR UNDERPASSES, ROAD TUNNELS AND THEIR ANCIILLARY BUILDINGS**

Underground Rapid Transit Systems, vehicular underpasses, road tunnels and their ancillary buildings must be stringently protected against flood risks. The salient principles and standards of protection to be complied with are outlined below:

**(A) STRINGENT CATCHMENT SEGREGATION**

[i.e. segregating the Underground Rapid Transit Systems, vehicular underpasses, road tunnels and their ancillary buildings from surface catchments and runoffs]

- Absolutely minimise the storm catchments of the Underground Rapid Transit Systems, vehicular underpasses, road tunnels and their ancillary buildings (such as by means of profile designs and roofing), and channel all at-grade and above-grade runoffs (eg. that from the roofs) into surface drains segregated from the underground facilities.
- Segregate the Underground Rapid Transit stations, tunnels, vehicular underpasses, road tunnels and their ancillary buildings by means of integrated water-tight barriers of at least 1.3 m above flood and ground levels.
- All ingress and egresses to the Underground Rapid Transit Systems, vehicular underpasses, road tunnels and their ancillary buildings (including pedestrian/traffic linkages and ventilation/services openings) are to be built with a segregation threshold of at least 1.3 m above road and ground levels.

**(B) RELIABLE PUMPED DRAINAGE SYSTEM**

[for removal of any water ingress that cannot be cut-off owing to constraints inherent in the Underground Rapid Transit System's, vehicular underpasses, road tunnels and their ancillary buildings interface with the surface tracks and linkages]

- Install an active pumping capacity equivalent to the 100-year return storm intensity corresponding to the time of concentration of the storm catchment (excluding the internal infiltration route of the tunnel surface) as determined from the Code of Practice on Surface Water Drainage, capped at 280mm/hour for a typical 10-minute concentration duration.
- Provide a bypass opening directly between Underground Rapid Transit Systems, vehicular underpasses, road tunnels and their ancillary buildings (including pedestrian/traffic linkages and ventilation/services openings) and storage tank below without any intermediate gratings
- Provide duplicated standby pumping equipment, including back-up pumps and pumping mains.
- Install standby fuel generators for uninterrupted operation of the pumping facilities.
- Construct pump sumps with an active operational storage capacity of 280mm (for 6-hour inflow) where sumps are accessible during train operations or 530mm (for 24-hour inflow) where sumps are inaccessible during train operations.
- Institute a well-regulated maintenance and operation procedure for the pumped drainage facilities.

The Pumped Drainage System (PDS) shall be fully automated with a supervisory monitoring system in place to allow operators to remotely monitor the water level in the pump sump and critical operation status of the pumps such as “start”, “stop” and “tripped”. An independent water level sensor, dedicated to detect the extreme high sump water level shall be in place. This extreme high sump water level shall be monitored by the supervisory monitoring system and a siren shall be triggered upon detection.

**(C) DEVELOPMENT CONTROL OF ALL CONNECTED DEVELOPMENTS**

[such that the same principles and standards of flood protection in (A) & (B) above are applied to all developments/facilities with existing/proposed linkages to the Underground Rapid Transit System, vehicular underpasses, road tunnels and their ancillary buildings (including pedestrian/traffic linkages and ventilation/services openings)]

- Carry out advanced, comprehensive planning of all proposed linkages to the Underground Rapid Transit System.
- Implement the same flood protection safeguards mentioned above for all such developments.

**(D) OPERATIONAL AND MANAGEMENT CONTROL**

[to ensure continued functioning and safeguarding of the protection measures implemented under (A), (B) & (C)]

- Have in place a comprehensive map/database of the overall underground networks with linkages to the Underground Rapid Transit System vehicular underpasses, road tunnels and their ancillary buildings (including pedestrian/traffic linkages and ventilation/services openings).
- Subject all building and development planning (including Addition & Alteration and reconstruction) of such linked developments/facilities to the vetting and control of the Land Transport Authority.
- Institute stringent operational and management measures to be undertaken by the owners of the linked developments/facilities under the supervision of Land Transport Authority.

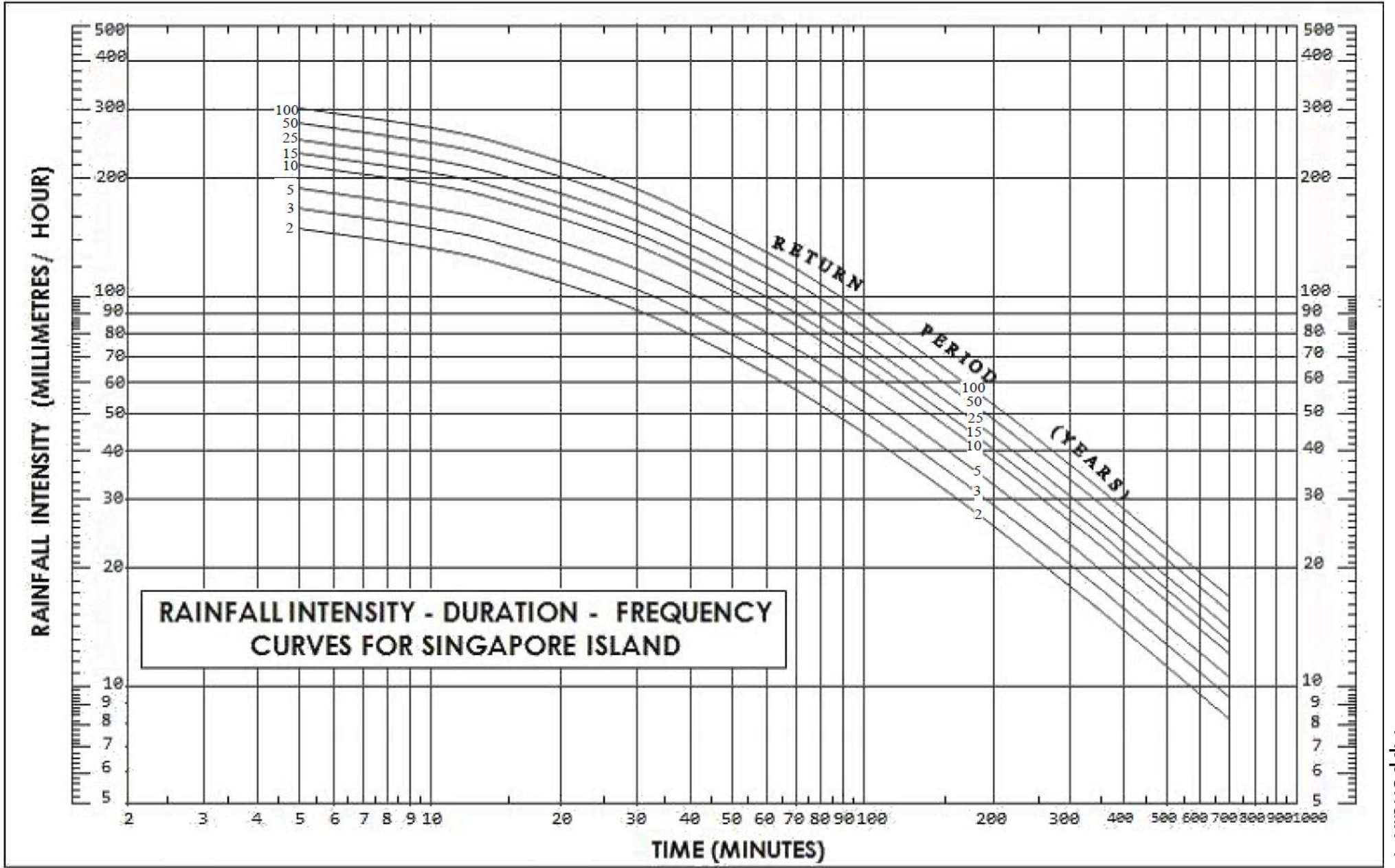

## SUBMISSION REQUIREMENTS FOR “AS-CONSTRUCTED” DRAINAGE DRAWINGS

- (a) The “As-Constructed” drawings shall be submitted in CAD and PDF format. The “As-Constructed” drawings shall be endorsed by a Professional Engineer and, where applicable, also by a Registered Surveyor.
- (b) The “As-Constructed” drawings shall be prepared in SVY21 coordinates. Note of survey such as date of survey, datum, coordinate system accuracies and tolerances, as stipulated in
- Standard and Specifications for 3D Topographic Surveying (Mapping) in Singapore
  - Standard and Specifications for Utility Survey in Singapore
- (c) The “As-Constructed” drawings shall show the following details:
- (i) Alignment and width of the drainage reserve.
  - (ii) Size and type of the constructed drain within the drainage reserve.
  - (iii) Longitudinal section showing the gradient, invert and cope level of the constructed drain.
  - (iv) Cross-section of the constructed drain in relation to the drainage reserve/lot boundary/retaining wall/boundary fence.
  - (v) Locations, sizes and types of all drain connections.
  - (vi) Piling records for drains and structures within the drainage reserve and roadside drains including entrance culverts. The piling records shall include the extent of piling, sizes, types, lengths and spacing of the piles. Reasons shall be stated if no piling is carried out.
  - (vii) Details of structures within drainage reserve such as bridge, crossing over drain, pedestrian crossing including the geographic co-ordinates.
  - (viii) Geographic co-ordinates (X and Y co-ordinates) of drainage appurtenances (e.g. gratings, drop inlet chambers, scupper mouth, scupper drain, railings etc.)
  - (ix) Structures (including piling records) beside drainage reserve, as and when required by the Board.
- (d) The “As-Constructed” drawings for structural detention and retention features (including drains that are used fully/partially for detention) shall show the following details:
- (i) Site plan indicating the type, dimension and volume of the constructed structural detention and retention features in the development site
  - (ii) Longitudinal section showing the gradient, invert and cope level of the constructed structural detention and retention features
  - (iii) Cross-section of the constructed detention tank(s)/drains showing the pumping facilities & swan neck pipe (if applicable), the effective depth of the structural detention and retention features including the connection points to the internal and public drainage system

- (e) The “As-Constructed” drawings for ABC Waters design features should include the following details:
  - (i) Site plan for ABC Waters design features with surrounding ground levels, invert level of the features, top levels, dimensions and invert levels for overflow sumps etc.
  - (ii) Cross-section/profiles of the features with levels and dimensions
  - (iii) Locations, levels and dimensions of overflow sumps, check dam, flushing pipes and other ancillary (as applicable).
  - (iv) Longitudinal profiles (for swales) showing the gradient, invert and cope levels
  - (v) Geographic co-ordinates (X and Y co-ordinates) of all ABC features and accompanying appurtenances (e.g. railings, decks, seating, gabion walls, lightings, play equipment etc.)
  
- (f) Records of piles installed shall be submitted in Excel sheet format in accordance with the forms stipulated in BCA, Building Control & Management, Record Structural Plan and Test Records.

This drawing shows schematically the drainage channels and minimum structural requirements. Details of the structural, geotechnical and foundation systems are to be designed by Qualified Persons.

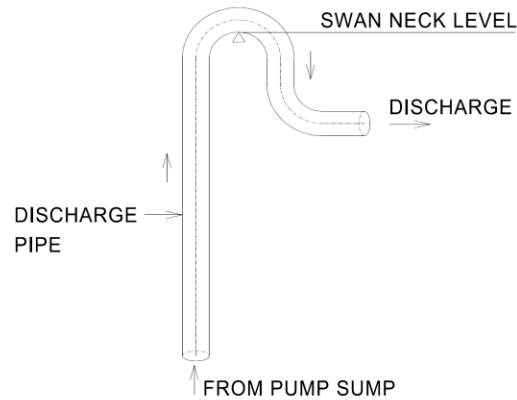

SCHEMATIC DIAGRAM OF SWAN NECK CONNECTION

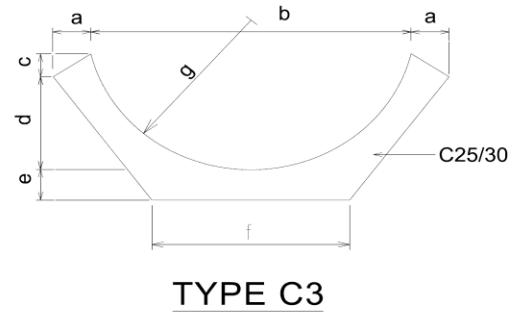

TYPE	a	b	c	d	e	f	g
C3	45	305	20	105	40	200	R155

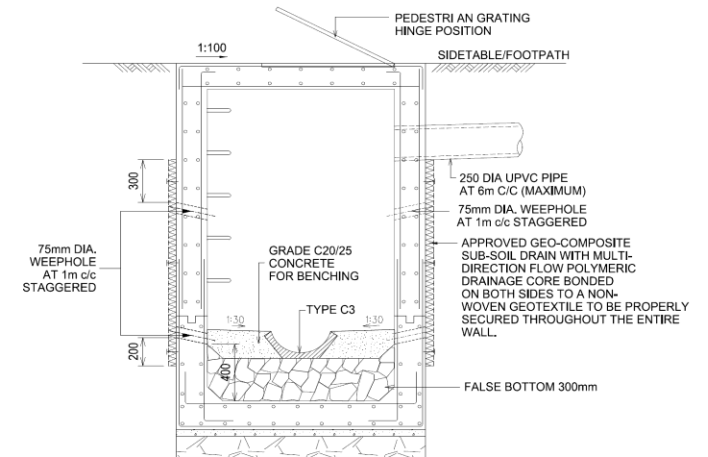

TYPICAL LAYOUT OF GEO-COMPOSITE  
(PILING AND FOUNDATION TO BE DESIGNED BY QP)  
N.T.S.

**NOTES:**

1. ALL DIMENSIONS ARE IN MILLIMETRES UNLESS OTHERWISE STATED
2. THE TOP SLAB OF THE ROADSIDE DRAIN SHALL BE CONSTRUCTED SUCH THAT WATER STAGNATION AT THE TOP SLAB WILL NOT OCCUR
3. LENGTH OF PRECAST OF C3 SHALL BE 500mm
4. MINIMUM C28/35 CONCRETE TO BE USED FOR THE PRECAST CONCRETE U-DRAIN AND BOX DRAIN (SLABBED OVER U-DRAIN)
5. THE DESIGN SURCHARGE LOAD FOR THE DRAINS SHALL COMPLY WITH CLAUSE 9.13 AND LATEST REQUIREMENTS OF LTA'S STANDARD DETAILS OF ROAD ELEMENTS
6. THE GEO-COMPOSITE SUB-SOIL DRAIN SHALL HAVE A MINIMUM HORIZONTAL DRAIN CAPACITY OF 0.1 LITRE/METRE/SECOND AT HYDRAULIC GRADIENT OF 0.04
7. CLEAR COVER TO REINFORCEMENT SHALL BE 40mm
8. THE SWAN NECK OUTLET IS PROPOSED TO BE CONNECTED TO AN INTERNAL DRAIN / SUMP BEFORE DISCHARGING INTO THE ROADSIDE DRAIN. PRESSURISE FLOW DISCHARGE DIRECTLY INTO THE ROADSIDE DRAIN SHOULD BE AVOIDED
9. STRUCTURAL DETAILS OF RUNG TO BE DESIGNED BY QUALIFIED PERSON

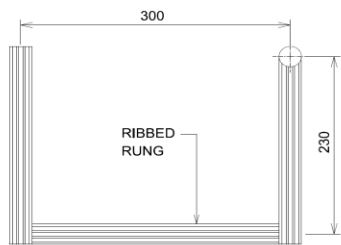

(CLOSED-UP VIEW OF RUNG)  
PLAN VIEW

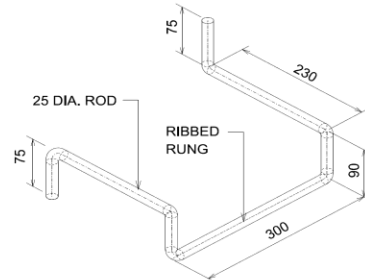

ISOMETRIC VIEW

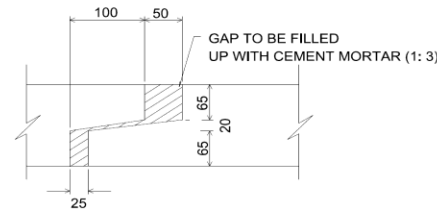

DETAILS OF REBATED JOINT

DETAILS OF NON-SKID ALUMINIUM RUNG

This drawing shows schematically the drainage channels and minimum structural requirements. Details of the structural, geotechnical and foundation systems are to be designed by Qualified Persons.

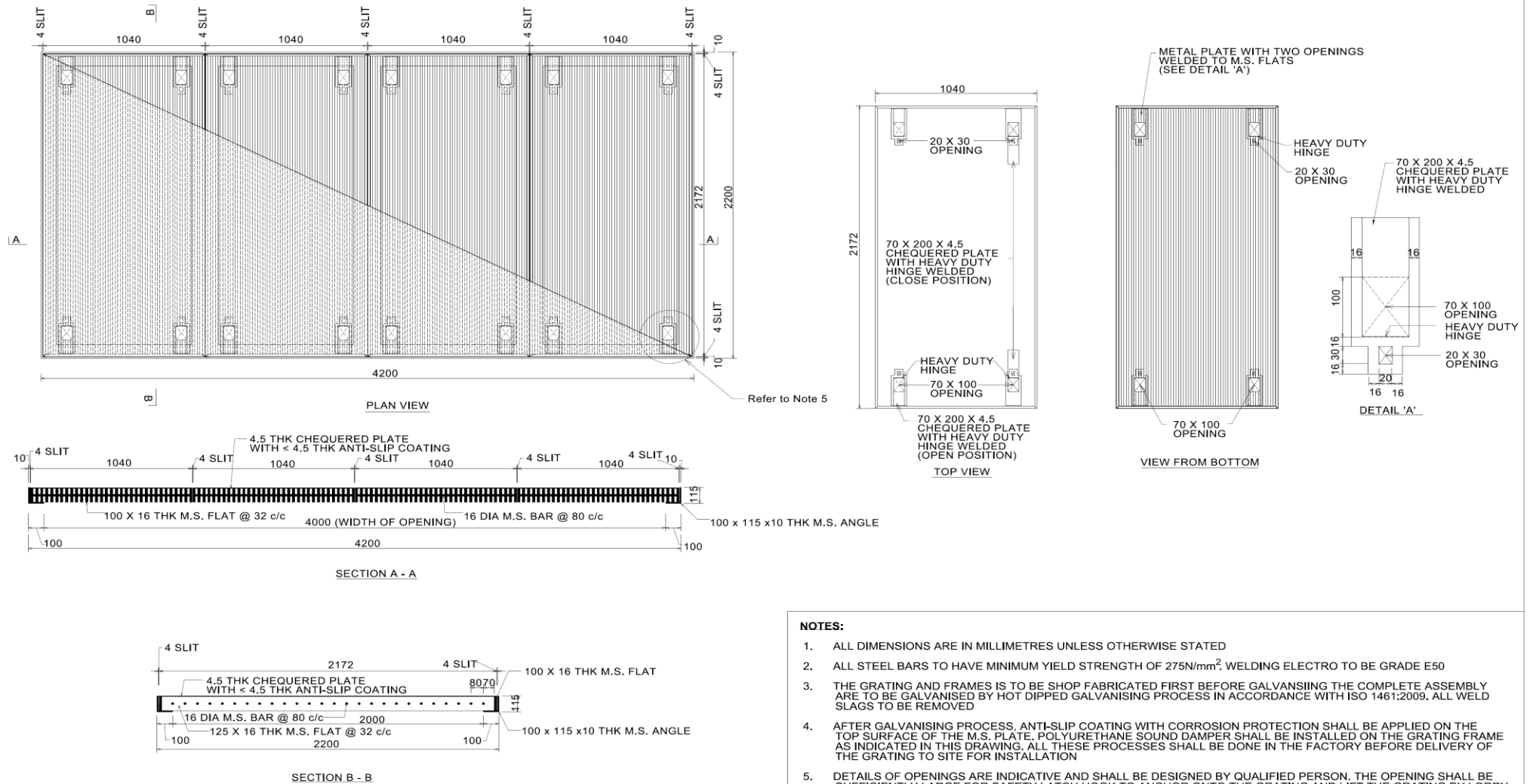

**NOTES:**

1. ALL DIMENSIONS ARE IN MILLIMETRES UNLESS OTHERWISE STATED
2. ALL STEEL BARS TO HAVE MINIMUM YIELD STRENGTH OF 275N/mm<sup>2</sup>. WELDING ELECTRO TO BE GRADE E50
3. THE GRATING AND FRAMES IS TO BE SHOP FABRICATED FIRST BEFORE GALVANISING THE COMPLETE ASSEMBLY ARE TO BE GALVANISED BY HOT DIPPED GALVANISING PROCESS IN ACCORDANCE WITH ISO 1461:2009. ALL WELD SLAGS TO BE REMOVED
4. AFTER GALVANISING PROCESS, ANTI-SLIP COATING WITH CORROSION PROTECTION SHALL BE APPLIED ON THE TOP SURFACE OF THE M.S. PLATE. POLYURETHANE SOUND DAMPER SHALL BE INSTALLED ON THE GRATING FRAME AS INDICATED IN THIS DRAWING. ALL THESE PROCESSES SHALL BE DONE IN THE FACTORY BEFORE DELIVERY OF THE GRATING TO SITE FOR INSTALLATION
5. DETAILS OF OPENINGS ARE INDICATIVE AND SHALL BE DESIGNED BY QUALIFIED PERSON. THE OPENING SHALL BE SUFFICIENTLY LARGE FOR SAFETY LATCH HOOK TO ANCHOR ONTO THE GRATING AND LIFT THE GRATING BY LORRY CRANE DURING INSPECTION AND MAINTENANCE



This drawing shows schematically the drainage facilities and minimum structural requirements. Details of the structural, geotechnical and foundation systems are to be designed by Qualified Persons.

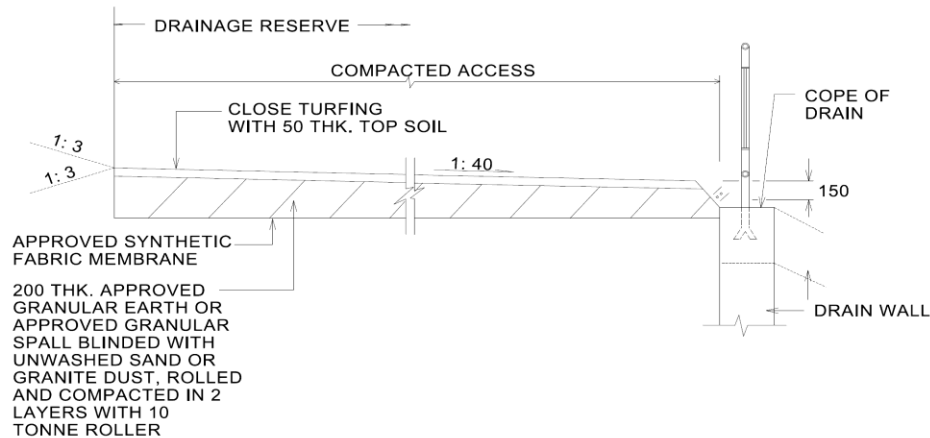

**DETAIL OF MAINTENANCE ACCESS  
AT DRAINAGE RESERVES**

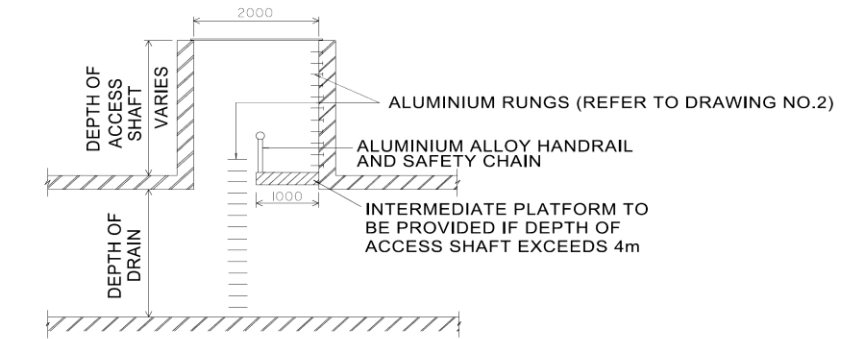

**SECTION N-N  
ACCESS SHAFT  
(FOR CLOSED DRAINS DEEPER THAN 3M)**

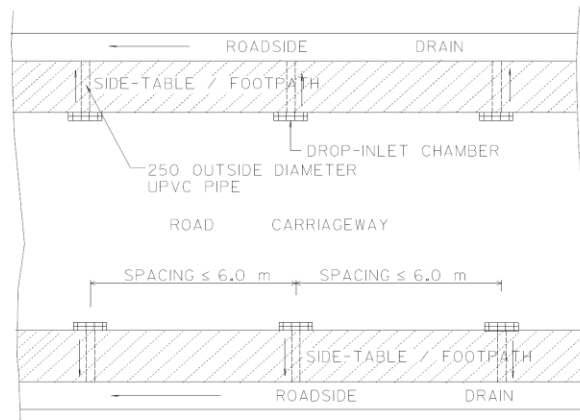

**SCHEMATIC PLAN VIEW**

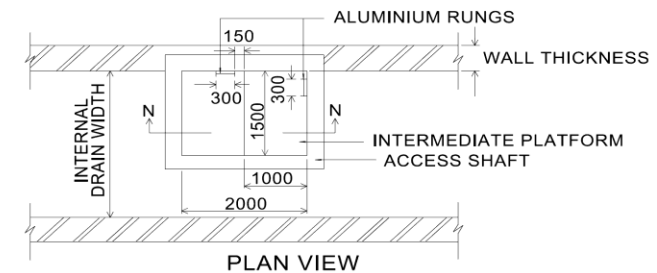

**PLAN VIEW**

**NOTES:**

1. ALL DIMENSIONS ARE IN MILLIMETRES UNLESS OTHERWISE STATED
2. ALL CONCRETE TO BE MINIMUM C20/25 UNLESS OTHERWISE STATED
3. THE STRUCTURAL DETAILS OF THE REINFORCED CONCRETE PAVEMENT SHALL BE DESIGNED TO WITHSTAND PEDESTRIAN LOADINGS IN ACCORDANCE WITH LAND TRANSPORT AUTHORITY'S REQUIREMENTS
4. SLOT-OUTLETS ARE TO BE PROVIDED FOR A MINIMUM DISTANCE OF 3 TIMES THE SIDE CARRIAGEWAY WIDTH OVER THE "BLIND" EDGE OF THE T-JUNCTION WHERE THE T-JUNCTION IS LOCATED AT A LOWER LEVEL THAN THE CONNECTING SIDE CARRIAGEWAY ALTERNATIVELY, DROP-INLET CHAMBERS ARE TO BE PROVIDED AT INTERVALS OF 3.0m OVER A MINIMUM DISTANCE OF 3 TIMES THE SIDE CARRIAGEWAY WIDTH

DRAWING NO. 3

STANDARD DETAILS OF MAINTENANCE ACCESS WITHIN DRAINAGE RESERVE, ACCESS SHAFT OPENING AND LAYOUT PLAN OF ROADSIDE DROP-INLET CHAMBERS AND SCUPPER PIPE DRAINS

This drawing shows schematically the drainage facilities and minimum structural requirements. Details of the structural, geotechnical and foundation systems are to be designed by Qualified Persons.

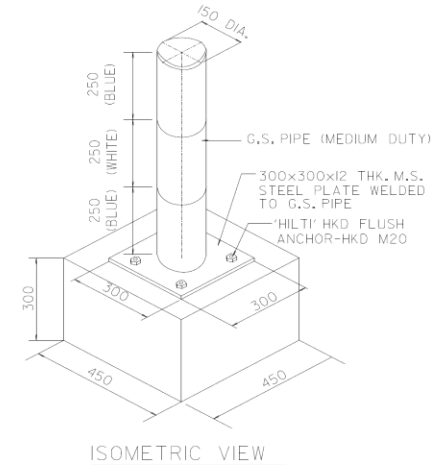
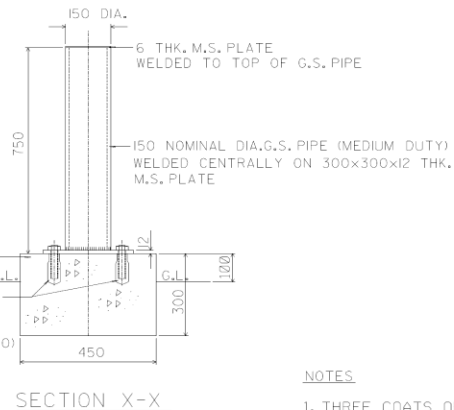
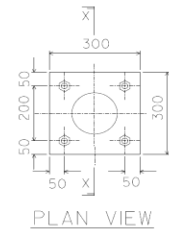
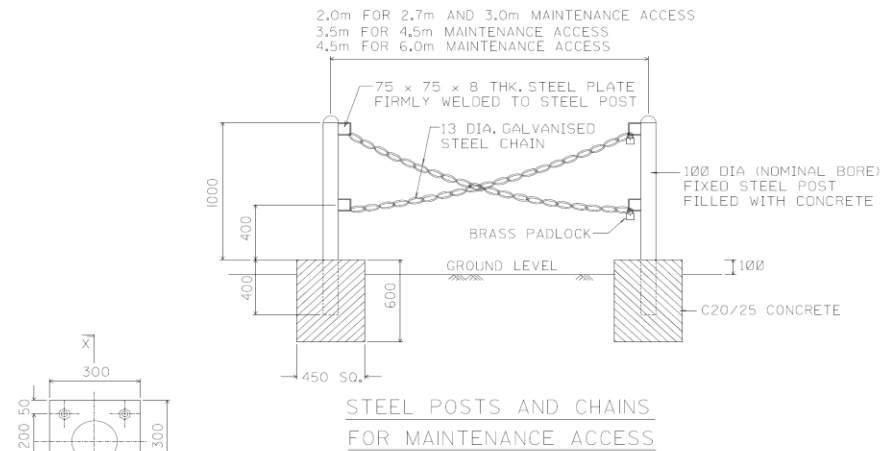
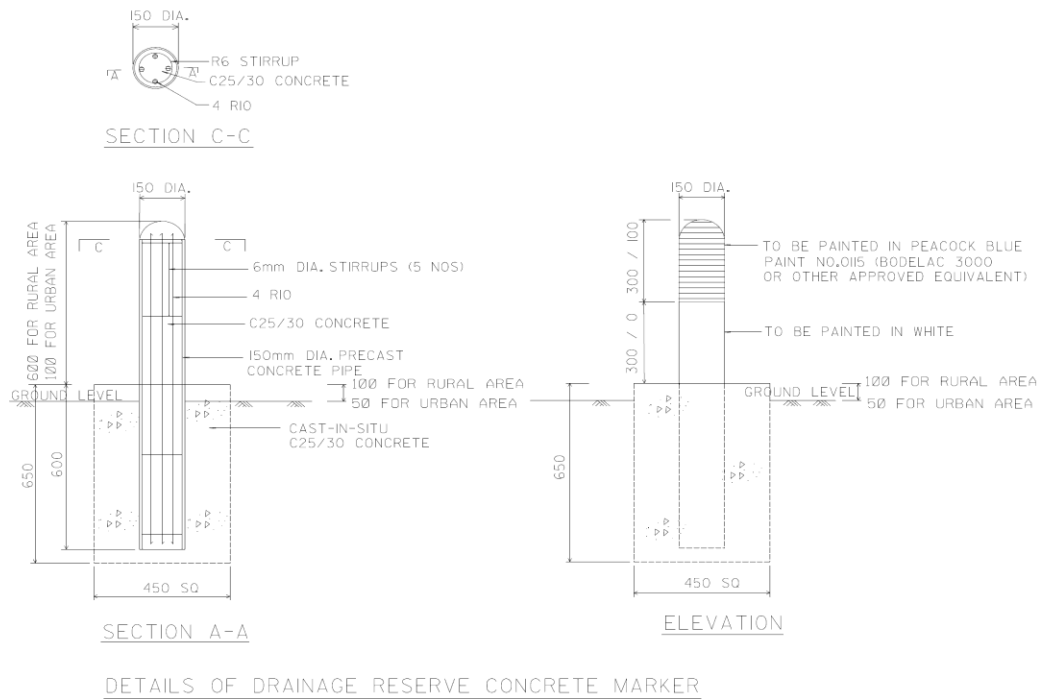

**NOTES:**

1. ALL DIMENSIONS SHOWN ARE IN MILLIMETRES UNLESS OTHERWISE STATED
2. MATERIALS
  - a) ALL G.S. PIPES OR EQUIVALENT TO BE LIGHT TUBES CONFORMING TO SS EN 10255:2013
  - b) ALL STEEL USED TO BE MILD STEEL CONFORMING TO SS EN 10025
  - c) ALL GALVANISING TO BE HOT DIPPED GALVANISED COATING CONFORMING TO BS EN ISO. 1461:2009
3. GALVANISED STEEL PIPES TO BE PREPARED AND PAINTED AS FOLLOWS:
  - a) ONE COAT OF APPROVED WASH PRIMER
  - b) ONE COAT OF APPROVED ZINC CHROMATE PAINT
  - c) ONE UNDERCOAT OF APPROVED OIL BASED PAINT
  - d) TWO TOP COATS OF APPROVED OIL BASED PAINT
4. ALL STEEL RODS, FLAT & SQUARE TO BE PREPARED AND PAINTED AS FOLLOWS:
  - a) BEFORE ERECTION CLEAN WITH WIRE BRUSH TO REMOVE ALL RUST & MILL SCALE AND PAINT ONE COAT OF APPROVED PRIMING PAINT
  - b) AFTER ERECTION PAINT ONE UNDERCOAT OF APPROVED OIL BASED PAINT AND TWO TOP COATS OF APPROVED OIL BASED PAINT

**NOTES**

1. THREE COATS OF APPROVED OIL BASED PAINT TO BE PAINTED ON BOLLARDS.
2. STEEL BASED PLATE BOLTS AND NUTS TO BE COATED WITH BITUMINOUS PAINT.

This drawing shows schematically the drainage channels and minimum structural requirements. Details of the structural, geotechnical and foundation systems are to be designed by Qualified Persons.

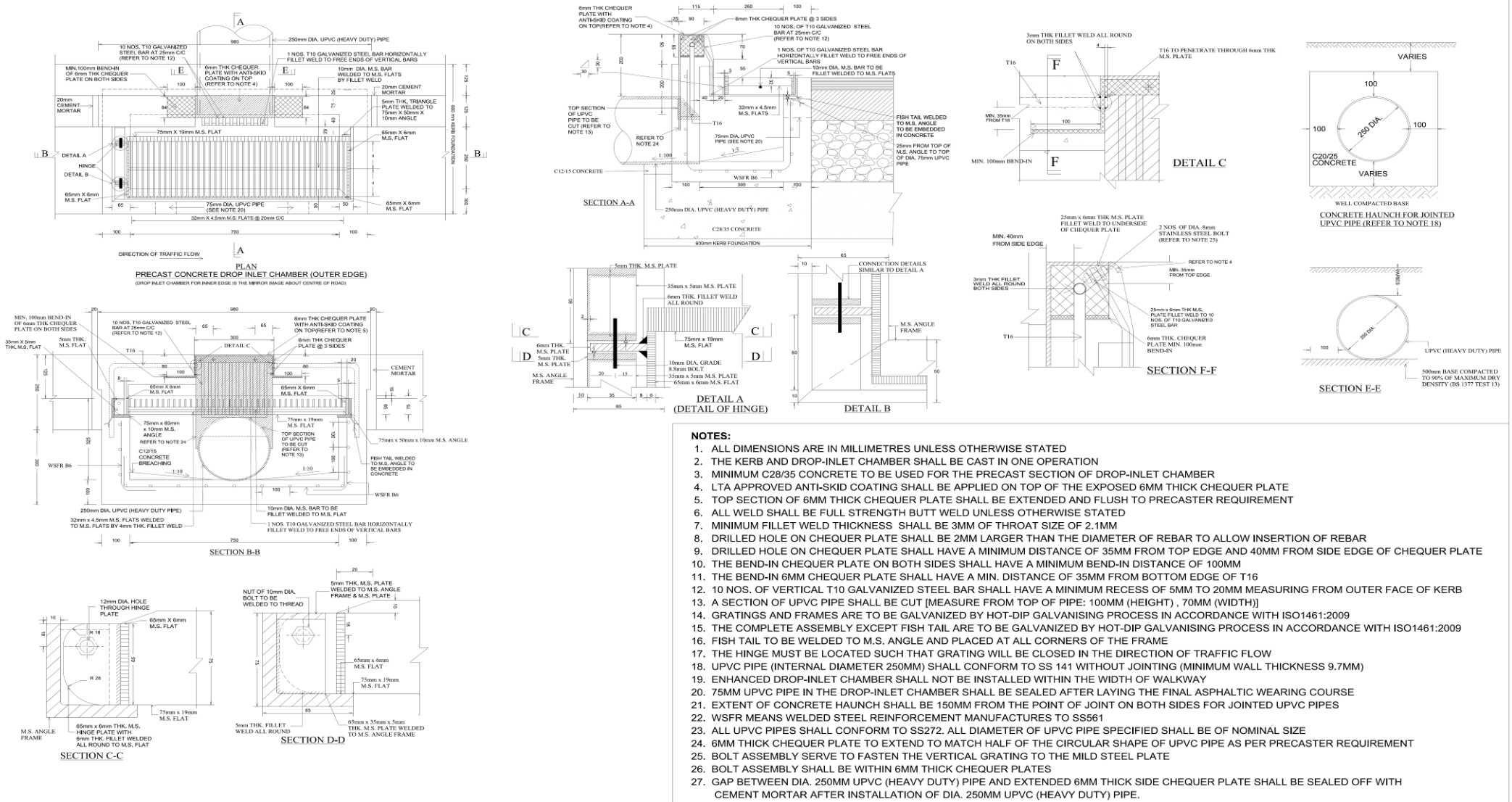

DRAWING NO. 5

ENHANCED DROP-INLET CHAMBERS

This drawing shows schematically the drainage facilities and minimum structural requirements. Details of the structural, geotechnical and foundation systems are to be designed by Qualified Persons.

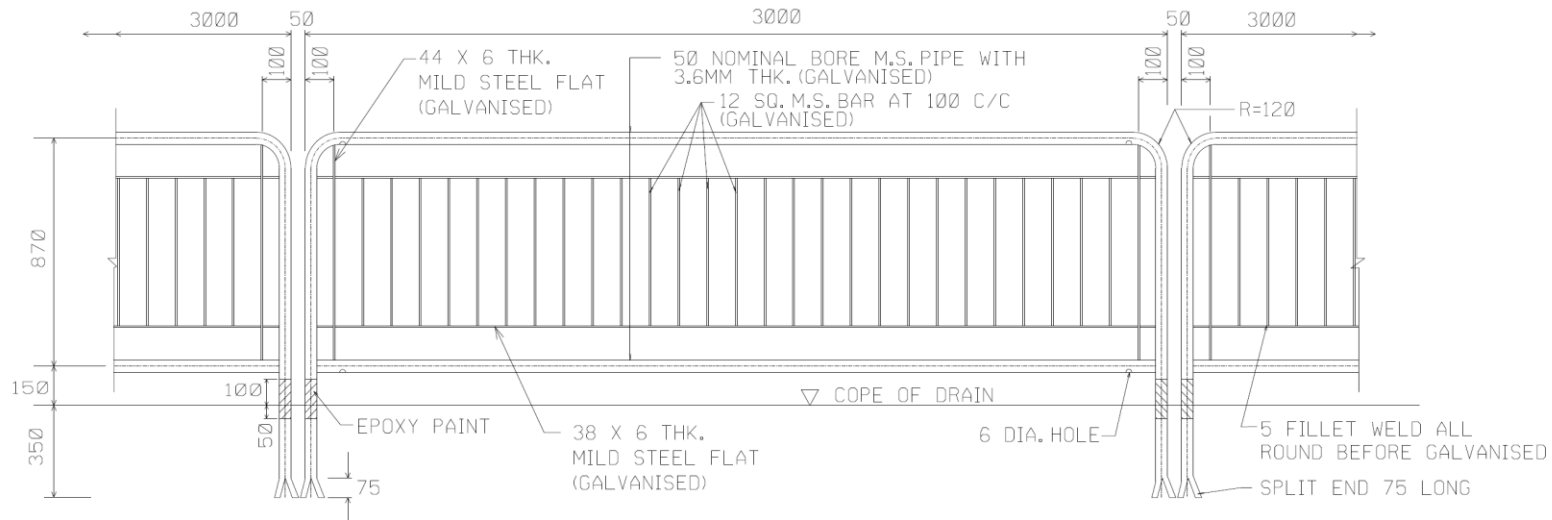

FRONT ELEVATION

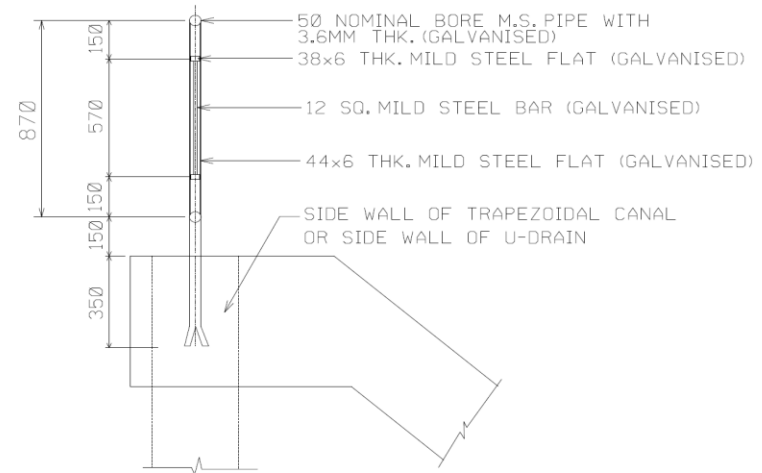

END ELEVATION

**NOTES:**

1. ALL DIMENSIONS ARE IN MILLIMETRES UNLESS OTHERWISE STATED
2. ALL JOINTS TO BE 5MM FILLET WELD
3. MATERIALS AND PREPARATION
  - a. MATERIALS USED SHALL COMPLY WITH THE LATEST STANDARDS AND REGULATIONS
  - b. ALL STEELS USED ARE TO BE MILD STEEL MATERIAL
  - c. G.S PIPE SHALL BE 50MM DIAMETER AND 3.6MM THICKNESS, MIN YIELD STRENGTH OF 355N/mm<sup>2</sup>
  - d. ALL STEEL PIPES, FLATS AND SQUARES ARE TO BE ASSEMBLED AND WELDED BEFORE GALVANISING
  - e. ALL WELDING SLAGS AND SPLATTERS SHALL BE REMOVED BY CHIPPING OR OTHER MECHANICAL MEANS BEFORE THE ENTIRE ASSEMBLED RAILING IS HOT-DIPPED GALVANISED
  - f. THE HOT-DIPPED GALVANISED SHALL BE DONE ACCORDANCE WITH ISO 1461:2009
4. PAINTING
  - a. ONE COAT OF APPROVED ETCH PRIMER
  - b. ONE COAT OF APPROVED ZINC CHROMATE PAINT
  - c. ONE UNDERCOAT OF APPROVED OIL BASED PAINT
  - d. TWO TOP COATS OF APPROVED OIL BASED PAINT OF COLOUR REFERENCE BRILLANT GREEN COLOUR CODE, BS221 (WHERE 1 COAT TO BE PAINTED BEFORE END OF DEFECT LIABILITY PERIOD)

DRAWING NO. 6

STANDARD SAFETY RAILINGS

This drawing shows schematically the drainage channels and minimum structural requirements. Details of the structural, geotechnical and foundation systems are to be designed by Qualified Persons.

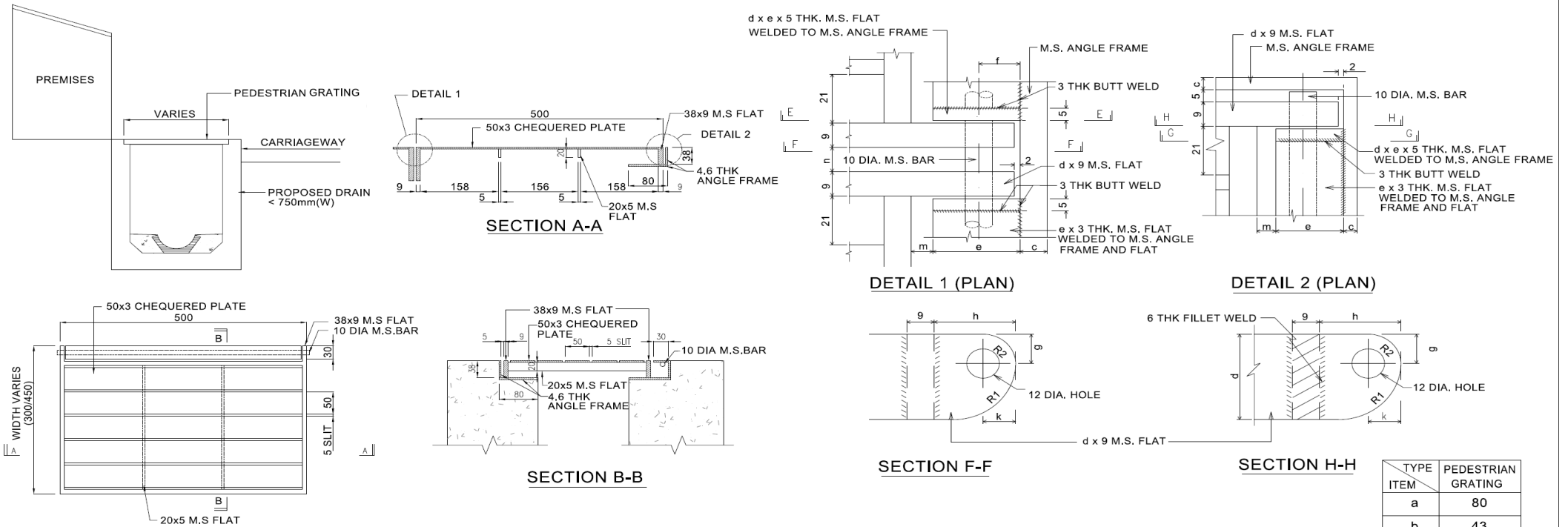

**NOTES:**

1. ALL DIMENSIONS ARE IN MILLIMETRES UNLESS OTHERWISE STATED
2. M.S. FLATS SHALL BE HOT DIPPED GALVANISED AND PAINTED WITH TWO COATS OF BLACK BITUMINOUS PAINT
3. 'H' = HEIGHT OF DRAIN, 'W' = WIDTH OF DRAIN
4. ALL WELDING SHALL BE 3 mm FILLET WELDS
5. THE EMBEDMENT OF STEEL ANGLES IN DRAINS WALL SHALL BE 100mm
6. ANY HACKING OF DRAIN STRUCTURE FOR THE EMBEDMENT OF GRATING SHALL BE MADE GOOD WITH C25/30 CONCRETE TO THE FULL SATISFACTION OF THE BOARD
7. GRATINGS AND FRAMES ARE TO BE GALVANISED BY HOT-DIP GALVANISING PROCESS IN ACCORDANCE WITH ISO 1461:2009
8. THE HINGE SHALL BE LOCATED ON THE DRAIN WALL ADJACENT TO PREMISES
9. THE GRATINGS AND FRAMES SHALL COMPLY WITH SS363:214 (SPECIFICATION FOR STEEL GRATING FOR ROADS, DRAINS AND WALKWAYS)

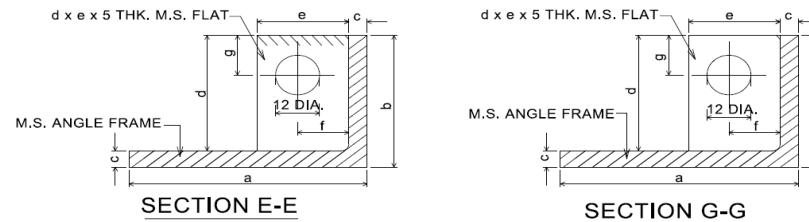

( REFER TABLE A FOR DIMENSION SHOWN IN ALPHABET )

TYPE ITEM	PEDESTRIAN GRATING
a	80
b	43
c	4.6
d	38
e	30
f	14
g	12
h	30
k	12
m	7
n	10
R1	23
R2	12

TABLE A

This drawing shows schematically the drainage channels and minimum structural requirements. Details of the structural, geotechnical and foundation systems are to be designed by Qualified Persons.

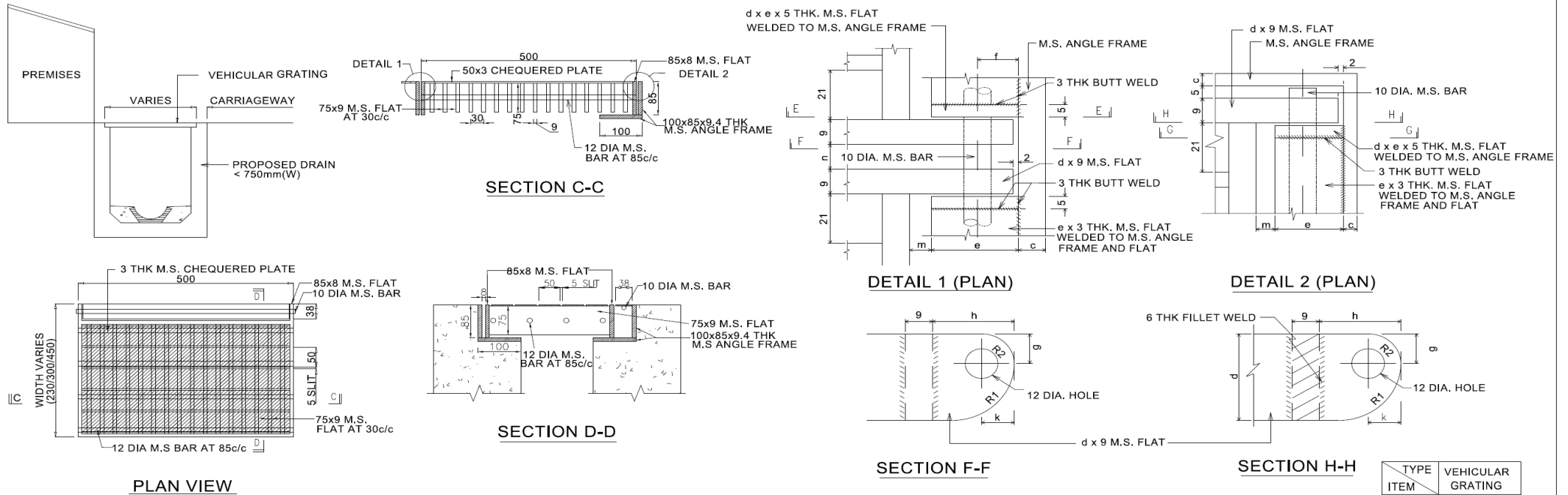

- NOTES:**
1. ALL DIMENSIONS ARE IN MILLIMETRES UNLESS OTHERWISE STATED
  2. M.S. FLATS SHALL BE HOT DIPPED GALVANISED AND PAINTED WITH TWO COATS OF BLACK BITUMINOUS PAINT
  3. 'H' = HEIGHT OF DRAIN, 'W' = WIDTH OF DRAIN
  4. ALL WELDING SHALL BE 8 mm FILLET WELDS
  5. THE EMBEDMENT OF STEEL ANGLES IN DRAINS WALL SHALL BE 100mm
  6. ANY HACKING OF DRAIN STRUCTURE FOR THE EMBEDMENT OF GRATING SHALL BE MADE GOOD WITH C25/30 CONCRETE TO THE FULL SATISFACTION OF THE BOARD
  7. GRATINGS AND FRAMES ARE TO BE GALVANISED BY HOT-DIP GALVANISING PROCESS IN ACCORDANCE WITH ISO 1461:2009
  8. THE HINGE SHALL BE LOCATED ON THE DRAIN WALL ADJACENT TO PREMISES
  9. THE GRATINGS AND FRAMES SHALL COMPLY WITH SS363:214 (SPECIFICATION FOR STEEL GRATING FOR ROADS, DRAINS AND WALKWAYS)
  10. ALL STRUCTURAL STEEL SHALL COMPLY WITH REQUIREMENTS OF SS EN 1993 OR SS EN 1994, WHICHEVER IS APPLICABLE. ALL STEEL MATERIAL TO BE FROM CERTIFIED LIST IN APPENDIX A OF BC1: ALL STRUCTURAL STEELWORK TO BE BRITISH / EUROPEAN (BS/EN) STRUCTURAL STEEL, GRADE S275, CLASS 1

TYPE ITEM	VEHICULAR GRATING
a	100
b	75
c	9.4
d	65
e	30
f	16
g	14
h	36
k	14
m	8
n	10
R1	28
R2	14

TABLE A

( REFER TABLE A FOR DIMENSION SHOWN IN ALPHABET )

This drawing shows schematically the drainage facilities and minimum structural requirements. Details of the structural, geotechnical and foundation systems are to be designed by Qualified Persons.

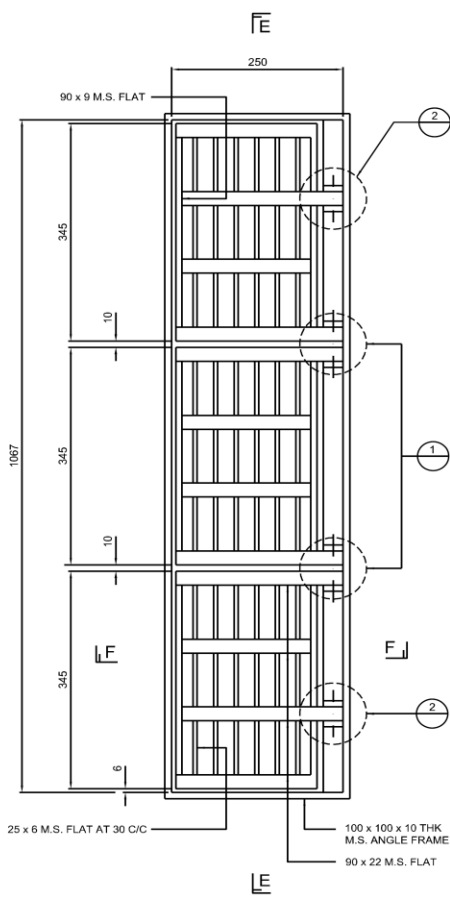

**250mm WIDE ENTRANCE CULVERT GRATING**  
SCALE 1:5

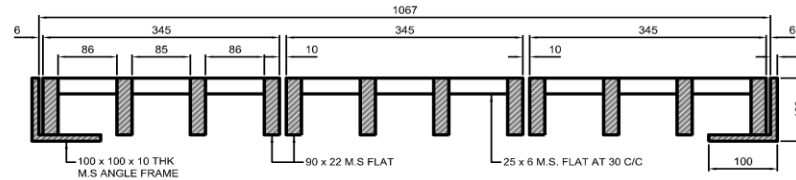

**SECTION E-E**  
SCALE 1:5

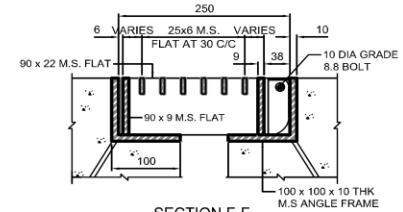

**SECTION F-F**  
SCALE 1:5

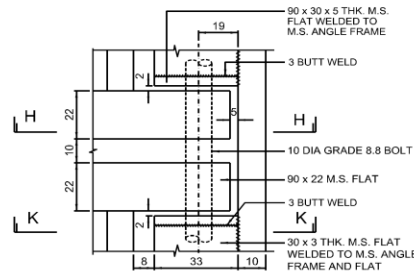

**DETAIL 1**  
PLAN  
SCALE 1:1

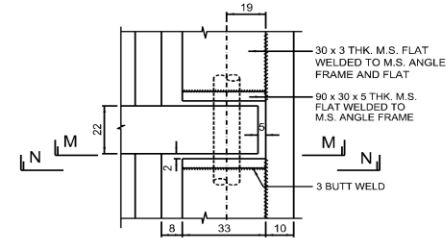

**DETAIL 2**  
PLAN  
SCALE 1:1

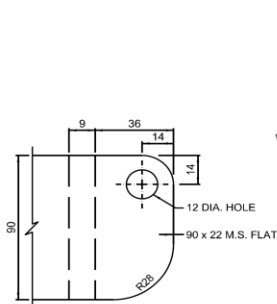

**SECTION H-H**  
SCALE 1:2

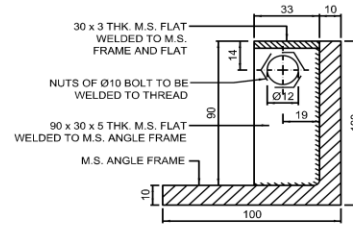

**SECTION K-K**  
SCALE 1:2

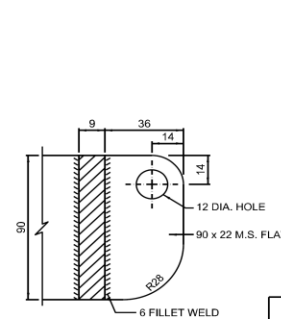

**SECTION M-M**  
SCALE 1:2

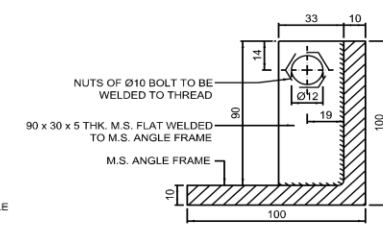

**SECTION N-N**  
SCALE 1:2

- NOTES:**
1. ALL DIMENSIONS SHOWN ARE IN MILLIMETRES UNLESS OTHERWISE STATED.
  2. GRATINGS AND FRAMES ARE SHOP FABRICATED AND ALL WELD SLAGS REMOVED.
  3. THE COMPLETE ASSEMBLY EXCEPT FISHTAILS IS GALVANISED BY HOT-DIP GALVANISING PROCESS IN ACCORDANCE WITH ISO 1461:2009.
  4. FISHTAILS ARE WELDED TO M.S. ANGLE AND PLACED AT ALL CORNERS OF THE M.S. FRAME.
  5. ALL THE FLATS AND ANGLES ARE FILLET WELDED THROUGHOUT.
  6. ALTHOUGH THE M.S. GRATINGS DESIGNED REMAIN IN ITS POSITION WHEN OPENED MORE THAN 106°, ADEQUATE MEASURES SHOULD NONETHELESS BE TAKEN TO PREVENT IT FROM ACCIDENTALLY CLOSING WHEN IT IS OPENED.

This drawing shows typically the Earth Control Measures at construction site.  
 Details of the Earth Control Measures are to be designed by Qualified Erosion Control Professional (QECP).

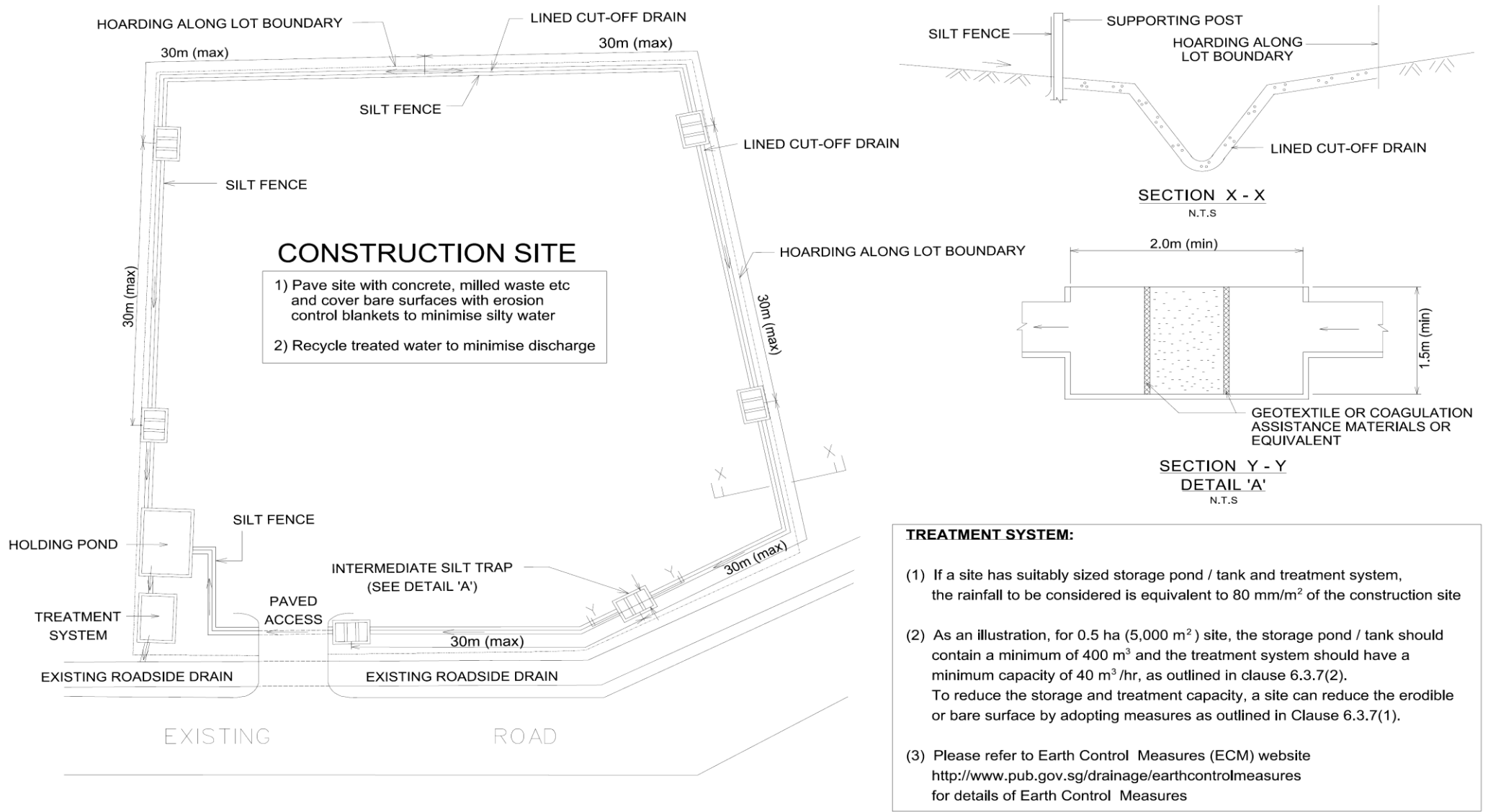

DRAWING NO. 8

EARTH CONTROL MEASURES AT CONSTRUCTION SITE