

- NOTES:
1. ALL DIMENSIONS ARE IN MILLIMETRES UNLESS OTHERWISE STATED.
 2. REFER TO THE GENERAL NOTES IN DRAWING NO. PUB/WSN/001.
 3. THE MANHOLE COVER AND FRAMES SHALL BE GRADE A1 AND COMPLY WITH SS30.
 4. LABEL ON MANHOLE COVERS SHALL BE:
PUB - PW FOR POTABLE WATER
PUB - NW FOR NEWATER
 5. MANHOLE COVERS FOR NEWATER PIPELINES SHALL BE PAINTED PURPLE (COLOUR CODE: 22-C-37).

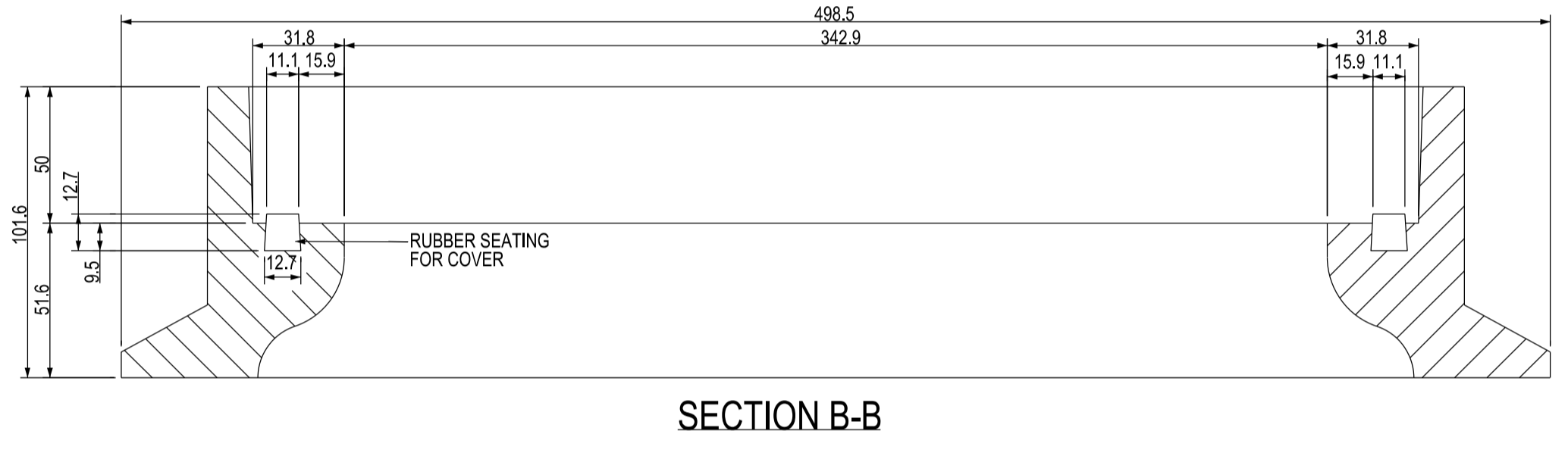

STANDARD SQUARE DUCTILE IRON (GRADE A1) MANHOLE FRAME AND COVER (FOR GROUND HYDRANT)

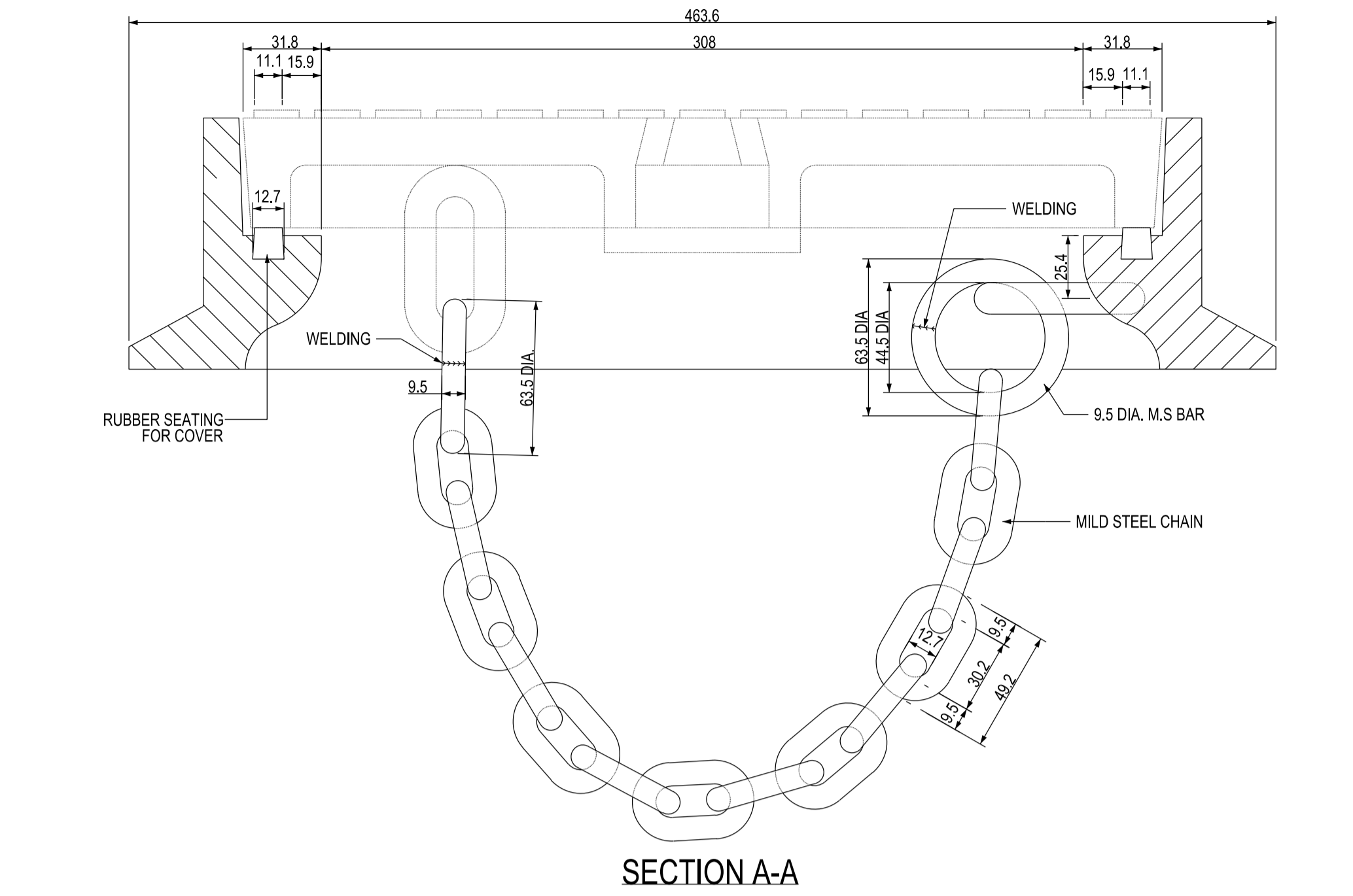
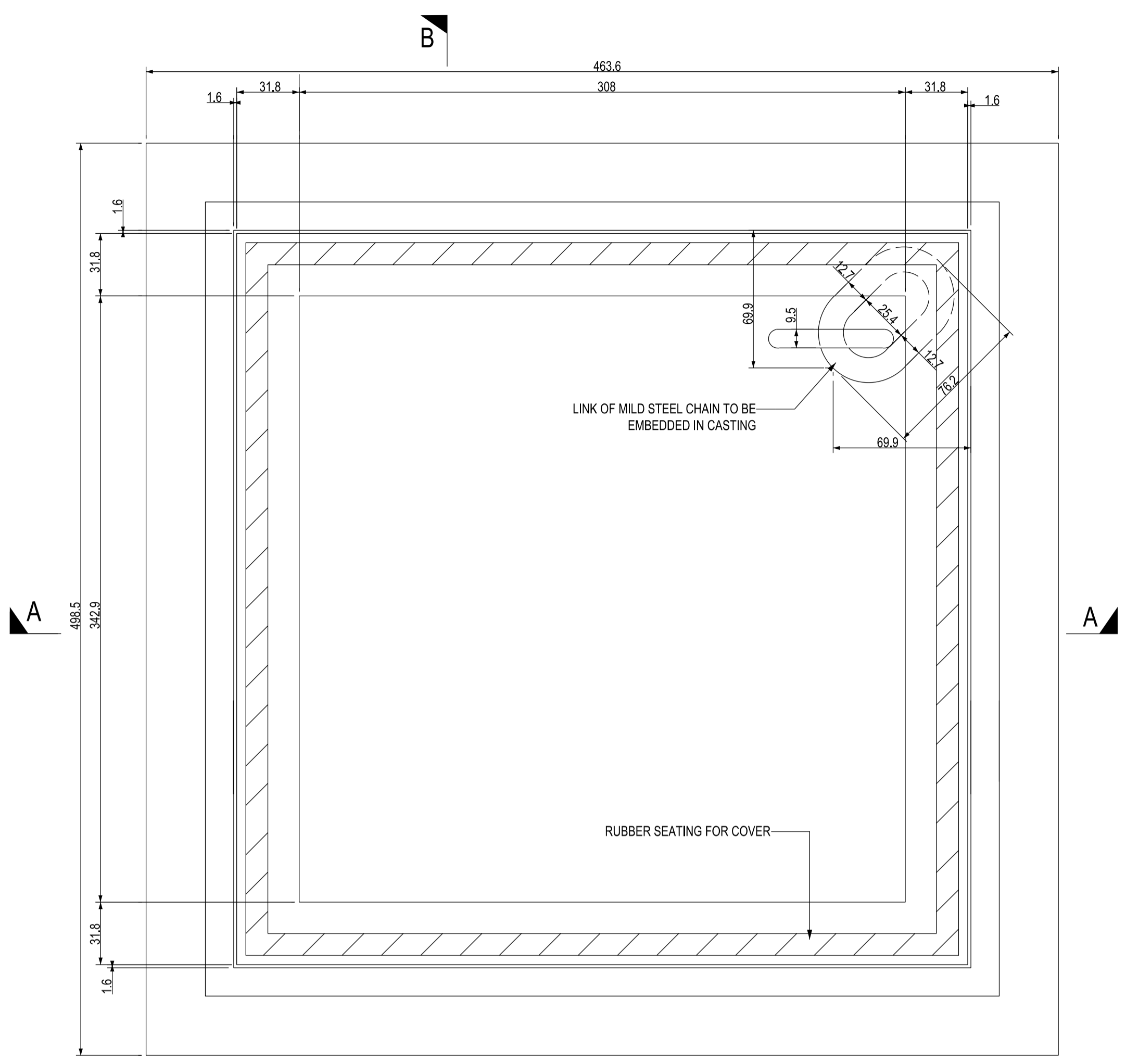
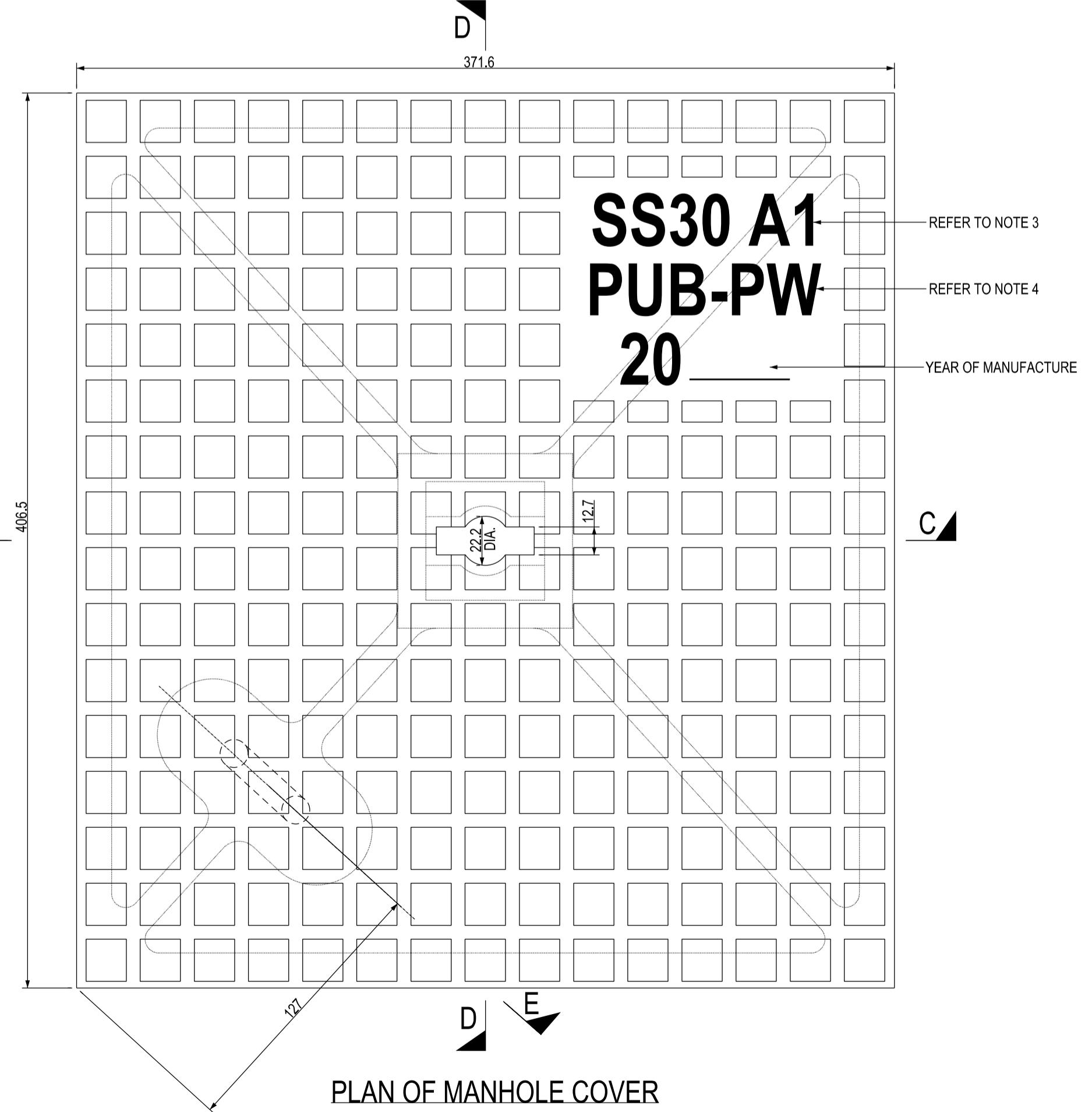
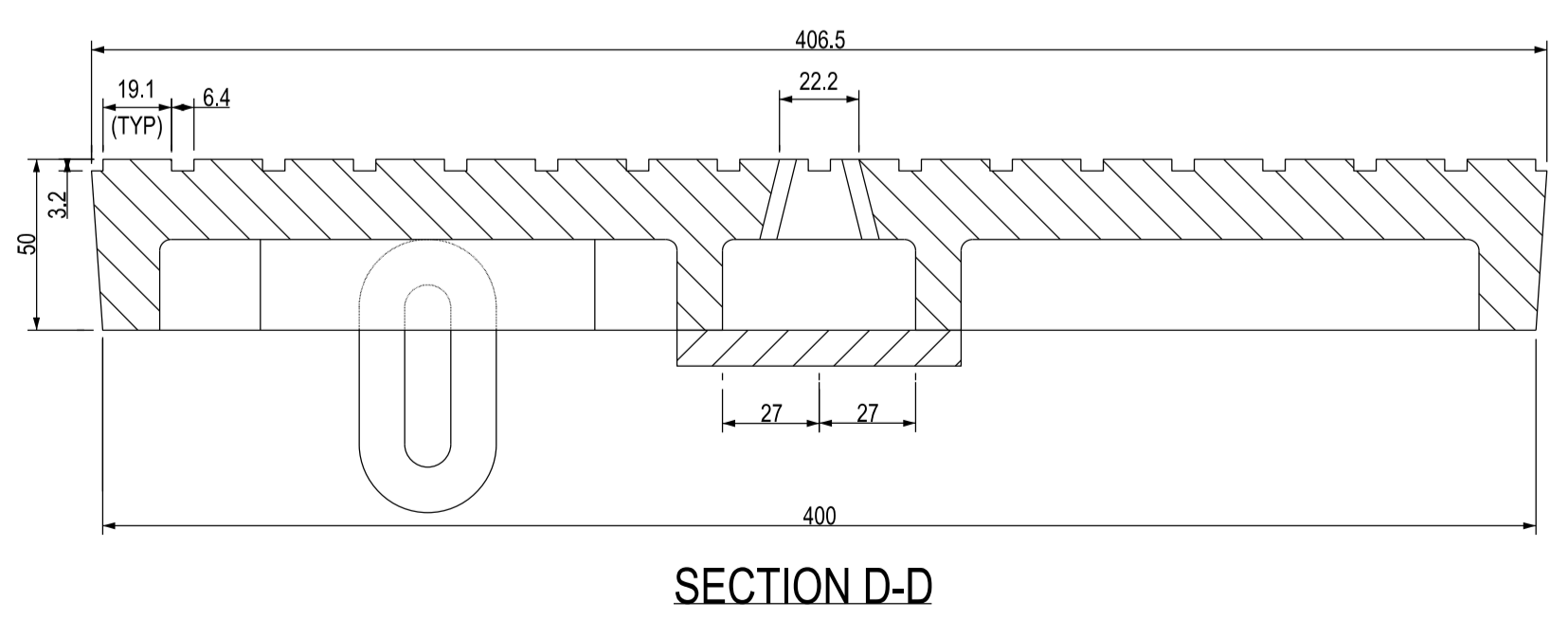
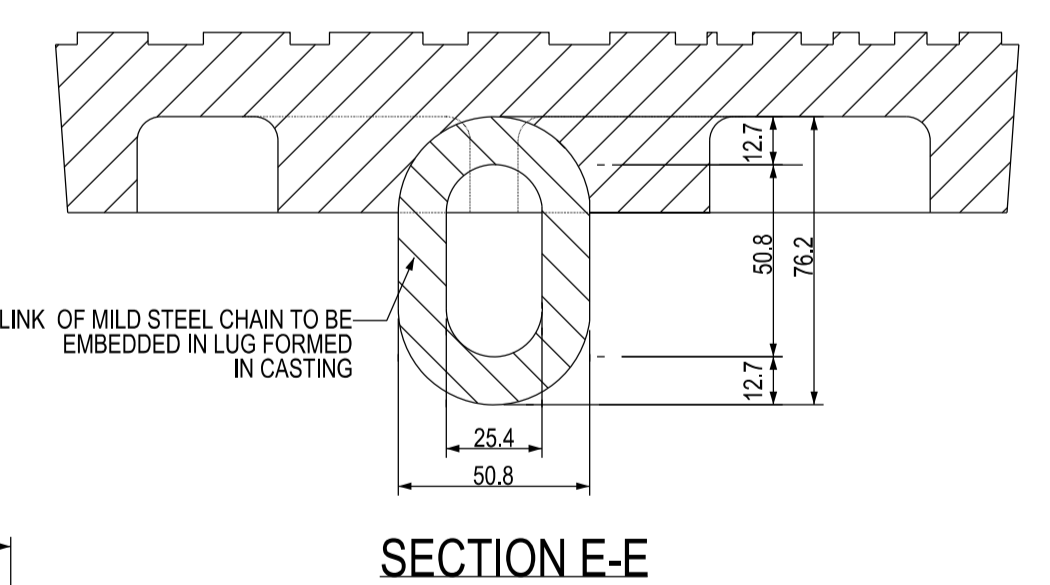
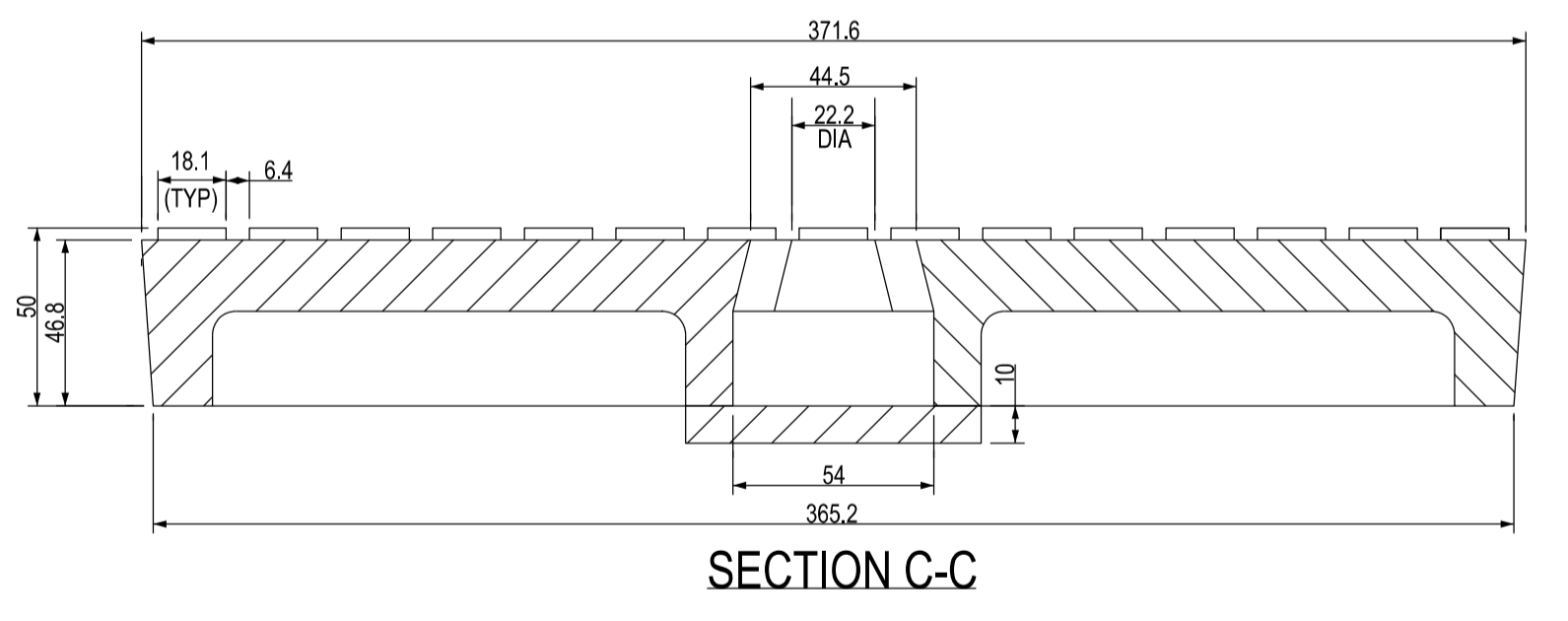

ISSUED: JUL 2017	SCALE	DRAWING NO.
LAST REVIEWED: AUG 2021	1:2	PUB/WSN/STD/206

STANDARD SQUARE DUCTILE IRON (GRADE A1) MANHOLE FRAME AND COVER (FOR GROUND HYDRANT)